



The Industry Voice for Workplace Solutions

General-Purpose Office Chairs - Tests

American National Standard for Office Furnishings





American National Standard

Approval of an American National Standard requires verification by ANSI that the requirements for due process, consensus, and other criteria have been met by the standards developer.

Consensus is established when, in the judgment of the ANSI Board of Standards Review, substantial agreement has been reached by directly and materially affected interests. Substantial agreement means much more than a simple majority, but not necessarily unanimity. Consensus requires that all views and objections be considered, and that a concerted effort be made toward their resolution.

The use of American National Standards is completely voluntary; their existence does not in any respect preclude anyone, whether he has approved the standard or not, from manufacturing, marketing, purchasing, or using products, processes, or procedures not conforming to the standard.

The American National Standards Institute does not develop standards and will in no circumstances give an interpretation of any American National Standard. Moreover, no person shall have the right or authority to issue an interpretation of an American National Standard in the name of the American National Standards Institute. Requests for interpretations should be addressed to the secretariat or sponsor whose name appears on the title page of this standard.

CAUTION NOTICE: This American National Standard may be revised or withdrawn at any time. The procedures of the American National Standards Institute require that action be taken periodically to reaffirm, revise, or withdraw this standard. Parties interested in American National Standards may receive current information on all standards by calling or writing the American National Standards Institute.

Published by



Copyright © 2011
All rights reserved

No part of this publication may be reproduced in any form, in an electronic retrieval system or otherwise, without prior written permission by the publisher.

Printed in the United States of America

**American National Standard
for Office Furnishings**

General-Purpose Office Chairs - Tests

**Sponsor
BIFMA International
678 Front Ave. NW, Suite 150
Grand Rapids, MI 49504
(616) 285-3963
email@bifma.org
www.bifma.org**

**Approved May 13, 2011
American National Standards Institute**



Foreword

The material presented in this standard was developed as a result of the efforts of the members of BIFMA International and reviewed by a broad representation of interested parties, government organizations and commercial testing and procurement and interior design organizations.

This standard defines specific tests, laboratory equipment, conditions of test, and recommended minimum levels to be used in the test and evaluation of the safety, durability, and structural adequacy of general-purpose office chairs.

The original work on this standard was completed in May 1974 by the BIFMA Engineering Committee and, particularly by its Subcommittee on Chair Standards. During the periods from February 1983 through January 1984, March 1990 through April 1993, September 1997 to October 2002, and again from September 2007 to April 2009 the Subcommittee on Chair Standards conducted reviews of the standard to ensure that the tests accurately describe the proper means of evaluating the safety, durability, and structural adequacy of general-purpose office chairs. The reviews produced revisions and/or additions to the various test procedures that improve the procedures and provide consistency. The revisions were submitted to the membership of BIFMA International for approval in May 2009 and again in November of 2010. The canvass of interested parties and stakeholders was conducted in accordance with the requirements of an ANSI accredited standards developer. After completion of the canvass process, the standard was subsequently submitted to the American National Standards Institute for approval as an American National Standard. Approval by ANSI was given on May 13, 2011.

Suggestions for the improvement of this standard are welcome. The suggestions should be sent to BIFMA International, 678 Front Ave NW, Suite 150, Grand Rapids, MI 49504-5368.

Contents

Section	Page
1 Scope	5
2 Definitions.....	6
3 General	8
3.1 Testing Considerations.....	8
3.2 Manufacturer's Instructions	9
3.3 Figures.....	9
3.4 Figure Symbols.....	9
3.5 Measurements.....	10
3.6 Tolerances.....	10
3.7 Test Force Application.....	10
3.8 Pretest Inspection.....	10
3.9 Recommended Test Report Format.....	11
4 Types of Chairs	13
5 Backrest Strength Test - Static - Type I	18
6 Backrest Strength Test - Static - Type II and III	23
7 Base Test - Static.....	26
8 Drop Test - Dynamic	28
9 Swivel Test - Cyclic	31
10 Tilt Mechanism Test - Cyclic	33
11 Seating Durability Tests - Cyclic.....	35
12 Stability Tests.....	38
13 Arm Strength Test - Vertical - Static.....	48
14 Arm Strength Test - Horizontal - Static.....	51
15 Backrest Durability Test - Cyclic - Type I	55
16 Backrest Durability Test - Cyclic - Type II and Type III	62
17 Caster/Chair Base Durability Test - Cyclic.....	67
18 Leg strength Test - Front and Side Application.....	73
19 Footrest Static Load Test - Vertical.....	76
20 Footrest Durability Test - Vertical - Cyclic	78
21 Arm Durability Test - Cyclic.....	79
22 Out Stop Tests for Chairs with Manually Adjustable Seat Depth	82
23 Tablet Arm Chair Static Load Test.	83
24 Tablet Arm Chair Load Ease Test - Cyclic.....	86
Appendix A: Impact Test Bag Construction Details	87
Appendix B: Stability Disk Construction Details.....	94

Table

1	Test Guide by Chair Type	14
---	--------------------------------	----

Figures

4	Types of Chairs	12
5	Backrest Strength Test - Static -Type I	15-17
6	Backrest Strength Test - Static - Type II and III	20-22
7	Base Test - Static.....	25
8	Drop Test - Dynamic	27
9	Swivel Test - Cyclic	30
10	Tilt Mechanism Test - Cyclic	32
11	Seating Durability Tests - Cyclic and Front Corner Load-Ease.....	34 & 36
12	Stability Tests	38, 40, 42-45
13	Arm Strength Test - Vertical - Static.....	47-48
14	Arm Strength Test - Horizontal - Static.....	50
15	Backrest Durability Test - Cyclic - Type I	52, 53, 54 & 57
16	Backrest Durability Test - Cyclic - Type II and Type III	59, 60, 61 & 64
17	Caster/Chair Base Durability Test - Cyclic	66 & 68
18	Leg Strength Test - Front and Side Application	71 & 72
19	Footrest Static Load Test - Vertical	75
20	Footrest Durability Test - Vertical - Cyclic	77
21	Arm Durability Test - Cyclic.....	79
22	Out Stop Test for Chairs with Manually Adjustable Seat Depth	81
23	Tablet Arm Chair Static Load Test	83
24	Tablet Arm Chair Load Ease Test - Cyclic	85

American National Standard
for Office Furnishings

General-Purpose Office Chairs - Tests

1 Scope

This standard is intended to provide manufacturers, specifiers, and users with a common basis for evaluating the safety, durability, and structural adequacy of general-purpose office chairs. General-purpose office chairs are normally used in an office environment and may include, but are not limited to those seating styles typically referred to as: executive/management, task/secretarial, side/guest chairs, stacking chairs, tablet arm chairs and stools.

This standard describes the means of evaluating general-purpose office chairs, independent of construction materials, manufacturing processes, mechanical designs or aesthetic designs. This standard does not address lounge seating, flammability, surface material durability, cushioning materials, product emissions, or ergonomic considerations.

The standard defines specific tests, the laboratory equipment that may be used, the conditions of tests, and the minimum acceptance levels to be used in evaluating general-purpose office chairs. The acceptance levels and test parameters given in this standard are based on the actual field use and test experience of BIFMA International members. Where appropriate, the CAESAR anthropometric database (2002 report), which indicates the 95th percentile male weighs 253 pounds, was used in the development of the tests. The tests were developed with an estimated product life of ten years based on single-shift usage. Product life will be affected by user size/weight, product use, care and maintenance, environment, and other factors, and, as such, product compliance to this standard does not necessarily guarantee a ten-year product life.

The tests in this standard are intended to assess the performance of new products only. They are not intended to assess a product that has been in use.

ISO 17025 requirements for measurement uncertainty do not apply to this standard.

2 Definitions

Note: Refer to BIFMA PD-1 Mechanical Test Definitions for related terms not included in this standard. Otherwise, the common dictionary definition shall be used for terms not defined in this section or in BIFMA PD-1. In case of a conflict between the definitions in this standard and PD-1, the definitions in this standard shall apply.

- 2.1 **acceptance level:** The performance level required to pass the test.
- 2.2 **appropriate rate:** Any rate that avoids resonant frequencies or excessive heating.
- 2.3 **back stop position:** The position of the unit when the unit's tilt mechanism first contacts its rearward mechanical stop, regardless of the force on the backrest.
- 2.4 **CMD:** The BIFMA Chair Measuring Device used for the measurement of seating products.
- 2.5 **CMD-1 Chair Measurement Procedure:** A universal procedure for the BIFMA Chair Measuring Device.
- 2.6 **cycle:** A complete operation of loading and unloading or of stress reversal; to open and close; one complete revolution; to operate in a cyclic manner.
- 2.7 **counterbalancing force:** A force or influence that offsets an opposing force.
- 2.8 **force:** A vector quantity, expressed in newton (N) or pounds force (lbf.) that tends to produce an acceleration of a body in the direction of its application.
- 2.9 **form-fitting device:** A device that distributes a force over a 305 ± 13 mm x 89 ± 13 mm (12 ± 0.5 in. x 3.5 ± 0.5 in.) area of a backrest. The device will be shaped to approximate the contours of the chair backrest.
- 2.10 **front stop position:** The position of the unit when the unit's tilt mechanism first contacts its forward mechanical stop.
- 2.11 **functional load:** The level of loading or force considered typical of hard use.
- 2.12 **IFD:** Indentation Force Deflection. See Test B₁, Indentation Force Deflection Test, in ASTM D 3574-08 Standard Methods for Flexible Cellular Materials - Slab, Bonded, and Molded Urethane Foams.
- 2.13 **lbf.:** Abbreviation for pounds-force. The corresponding unit in the SI (Système International) system is the newton (N).
- 2.14 **load:** The weight to which a structure is subjected; a weight or force applied to a product; force acting on a surface, usually caused by the action of gravity.
- 2.15 **load-bearing structure/surface:** Any element that supports loads during use. Foam and fabric, for example, are not generally considered load-bearing surfaces, nor are some portions of waterfall edges.
- 2.16 **loss of serviceability:** The failure of the product to support its intended load or to perform all of its normal functions or adjustments.

- 2.17 lounge seating:** Seating that is intended for use in indoor public spaces such as waiting, reception, or lounge areas. Lounge seating includes products with single seat units or units with multiple seating positions within one unit. Lounge seating may be fixed to the building structure or freestanding. It is generally not adjustable for personal use.
- 2.18 manufacturer's instructions:** Instructions for assembly, operation, and/or maintenance supplied by the manufacturer to the customer.
- 2.19 N (newton):** a unit of force in the SI (Système International) System, also known as the Metric System.
- 2.20 normal use condition:** For consistency, the midpoint of any adjustment range, such as the height adjustment or counter balancing force adjustment unless otherwise specified in the test method.
- 2.21 pedestal base:** A base that supports a chair by a single central structural member such as a column.
- 2.22 pivoting backrest:** A backrest that rotates on a horizontal axis above the height of the seat.
- 2.23 proof load:** The level of loading or force in excess of hard use.
- 2.24 stool:** A chair with a seat height greater than 610 mm (24 in.), intended to allow the user to sit at standing-height work surfaces such that the user's feet are not supported by the floor.
- 2.25 tablet arm:** A surface attached to a chair that has the primary function to support tasks such as writing and short-term reference material handling. These surfaces typically do not have independent support legs and are not intended to support a person's weight.
- 2.26 test platform:** The horizontal hard work surface, (concrete or other unyielding surface) on which the chair to be tested is placed during testing.
- 2.27 worst-case condition:** The product and/or condition (i.e. size and construction of a given unit type) most likely to be adversely affected by an individual test or testing sequence.

3 General

3.1 Testing Considerations

3.1.1 The testing and evaluation of a product according to this standard may require the use of materials and/or equipment that could be hazardous. This document does not purport to address all the safety aspects associated with the use of those materials and/or equipment. Anyone using this standard has the responsibility to consult the appropriate authorities and to establish health/safety practices and any applicable regulatory requirements prior to the use of the materials or equipment described.

3.1.2 The types of tests to be employed fall into the following general categories:

- a) Static load applications;
- b) Dynamic load applications;
- c) Durability and/or life cycle testing.

3.1.3 The tests described in this standard, other than the specifically identified component tests (i.e., base loading) are intended to evaluate the entire chair assembly, including the base, tilt mechanism, height adjustment device, locking/adjustment mechanisms, seat/backrest attachment, etc.

3.1.4 Each manufacturer's model or unit type in any configuration shall comply with applicable requirements when tested in accordance with this standard. Only worst-case models need to be tested for a specific unit type. A worst-case condition shall be representative of all models or units of the type tested. If "worst-case condition" is not readily evident, a case-by-case product line analysis by the manufacturer in consultation with the designated testing facility may be necessary, taking into consideration any special attributes, methods of construction, materials, and/or design features, etc.

3.1.5 The test methods included in this standard require the use of fixtures and/or load adapters to perform the tests. Some products and/or constructions may need special test fixtures, load adapters, etc., to perform these tests in a manner that meets the intent of the standard. This is especially true of products with complex articulation of joints, unique motions or adjustments, or non-traditional use of materials. The users of this standard are encouraged to develop appropriate fixtures and/or test variations that more accurately simulate application of loads, etc., for given unique products in a manner that reflects actual use. Fixtures, load adapters, etc., shall not add structure or provide support to the product being tested. If a test procedure cannot be performed as specified in the procedures due to the design of the product, it shall be carried out as far as possible as described, and deviations from the procedure shall be recorded in the test report (See Section 3.9). Independent/consumer testing facilities may need to consult with product manufacturers to ensure any special conditions are considered during testing.

3.1.6 It is not intended that all of the tests in this standard be conducted on a single unit. The tests may be performed on a series of units at the discretion of the manufacturer. When a test requires a functional load and a proof load be applied as part of the test criteria, the functional and proof loads shall be applied to the same component or unit. The tests may be performed in any sequence unless otherwise specified within a given test section; the functional load shall always precede the proof load.

3.1.7 Table 1 indicates the tests that shall be performed on each type of chair, as defined in Section 4.

3.2 Manufacturer's Instructions

Where supplied, manufacturer's assembly instructions shall be followed during the initial assembly or setup of the chair. When a manufacturer recommends specific instructions or maintenance adjustments that may be required in order to keep the product in good operating condition, unless otherwise specified by these test procedures, the manufacturer's assembly, operating and maintenance instructions shall be followed.

3.3 Figures

Figures provided in this standard are intended as guidelines only and may not be representative of all possible test configurations.

3.4 Figure Symbols

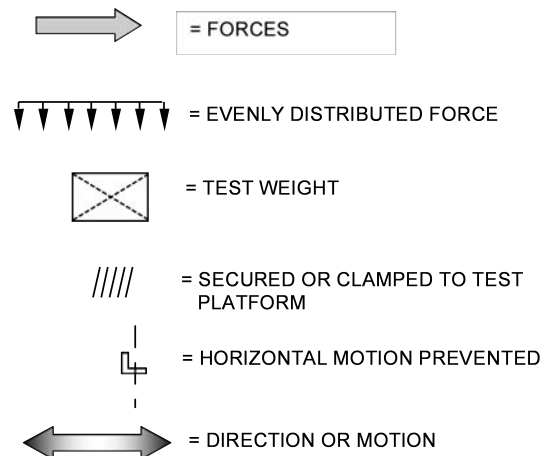

3.5 Measurements

The BIFMA Chair Measurement Device (CMD) is to be used in determining applicable setup measurements. The setup measurement may be determined for an individual model and used for all tests for that model. In order for measurements to be "universally" acceptable, only Chair Measuring Devices (CMD) built to BIFMA specifications may be used. The specifications and drawings are available from BIFMA International.

3.6 Tolerances

Unless otherwise specified, tolerances on test equipment, measuring equipment and loading devices, shall be:

- Test Weights, Forces, Velocities, and Time, $\pm 5\%$
- Linear measurements, ± 1.5 mm (1/16 in.)
- Angles, ± 5 degrees
- Level, within 5 mm per meter (0.06 in. per linear foot) or ± 0.3 degrees
- Cycle requirements are minimums.

Test weights, forces, dimensions, angles, times, rates and velocities shall be targeted at the nominal values specified.

3.7 Test Force Application

To ensure that negligible dynamic force is applied, the forces in the static force tests shall be applied sufficiently slowly until the target load/force is achieved. Where time limits are given, loads and forces shall be maintained according to the tolerance given in Section 3.6 unless otherwise specified.

3.8 Pretest Inspection

Before beginning the testing, visually inspect the unit thoroughly. Record any defects so that they are not assumed to have been caused by the tests.

3.9 Recommended Test Report Format

When a test report is required, the following information should be included:

1. A title: (i.e., "Test Report");
2. Name and address of the laboratory, and the location where the tests were carried out, if different from the address of the laboratory;
3. Unique identification of the report (such as serial number) and on each page an identification in order to insure that the page is recognized as part of the test report and a clear identification of the end of the test report;
4. Name and address of the client (where applicable);
5. Description and unambiguous identification of the item tested (i.e., model number, manufacturing date, etc.);
6. Characterization and condition of the test item;
7. Date of receipt of the test item;
8. Date(s) of the performance of test;
9. Identification of the test method used;
10. Any additions to, deviations from, or exclusions from the test method (such as environmental conditions);
11. The name(s), function(s) and signature(s), or equivalent identification of the person(s) authorizing the test report;
12. Where relevant, a statement to the effect that the results relate only to the items tested;
13. Date of issue of the report;
14. Test results with, where appropriate, the units of measurement and a statement of compliance/non-compliance with requirements and/or specifications;
15. A statement that the report shall not be reproduced, except in full, without the written approval of the laboratory.

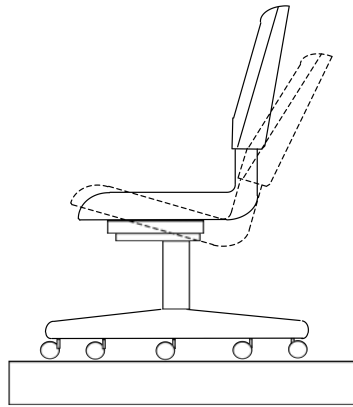

Figure 4a - Type I - Tilting Chair

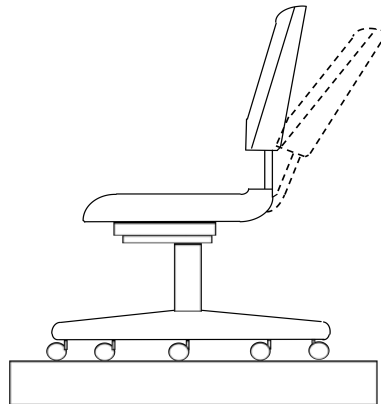

Figure 4b - Type II - Fixed seat angle, tilting backrest

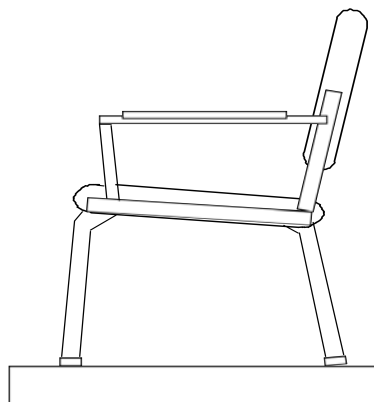

Figure 4c - Type III - Fixed seat angle, fixed backrest
Types of Chairs

4 Types of Chairs

To accommodate a wide variation in chair designs, it may be necessary to apply the tests to various types of chairs.

If a product can be classified as more than one chair type, it shall be tested under all applicable classifications. For example, a chair with a locking tilt mechanism would be classified as both a Type I (when the seat is unlocked) and Type III chair (when the seat is locked).

The following classification of types and features of chairs provides standard product identification:

4.1 Chair Type: **Type I. Tilting chair:**

A chair with a seat and backrest that tilt (either in unison or in synchronization) with a counterbalancing force. Chairs of this type are typically referred to as synchro-tilt, center-tilt, knee-tilt, etc.

(See Figure 4a)

Type II. Fixed seat angle, tilting backrest:

A chair that provides a fixed seat angle with a tilting backrest.

(See Figure 4b)

Type III. Fixed seat angle, fixed backrest:

A chair that provides a fixed seat angle with a fixed backrest.

This may include chairs with legs, including sled base chairs.

(See Figure 4c)

TABLE 1 – Test Guide by Chair Type

Section Number	Description	Type I	Type II	Type III
5	Backrest Strength Test - Static - Type I	X		
6	Backrest Strength Test - Static - Type II and III		X	X
7	Base Test - Static	X	X	X
8	Drop Test - Dynamic	X	X	X
9	Swivel Test - Cyclic	X	X	X
10	Tilt Mechanism Test - Cyclic	X	X	
11	Seating Durability Test - Cyclic	X	X	X
12	Stability Tests	X	X	X
13	Arm Strength Test - Vertical - Static	X	X	X
14	Arm Strength Test - Horizontal - Static	X	X	X
15	Backrest Durability Test - Cyclic - Type I	X		
16	Backrest Durability Test - Cyclic - Type II and Type III		X	X
17	Caster/Chair Base Durability Test - Cyclic	X	X	X
18	Leg Strength Test - Front and Side Application	X	X	X
19	Footrest Static Load Test - Vertical	X	X	X
20	Footrest Durability Test - Vertical - Cyclic	X	X	X
21	Arm Durability Test - Cyclic	X	X	X
22	Out Stop Test for Chairs with Manually Adjustable Seat Depth	X	X	X
23	Tablet Arm Chair Static Load Test	X	X	X
24	Tablet Arm Chair Load Ease Test - Cyclic	X	X	X

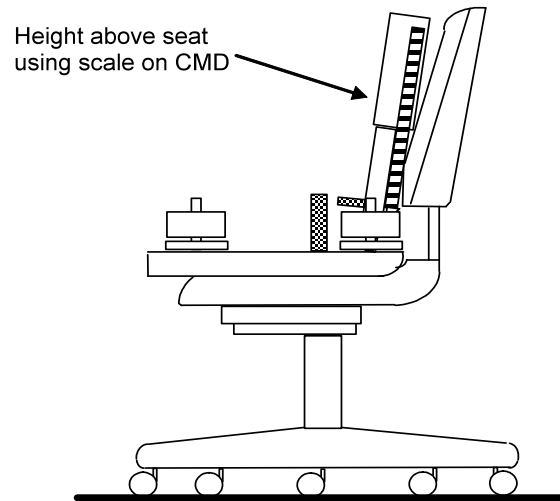

**Figure 5a - Height Determination
Backrest Strength Test - Static - Type I**

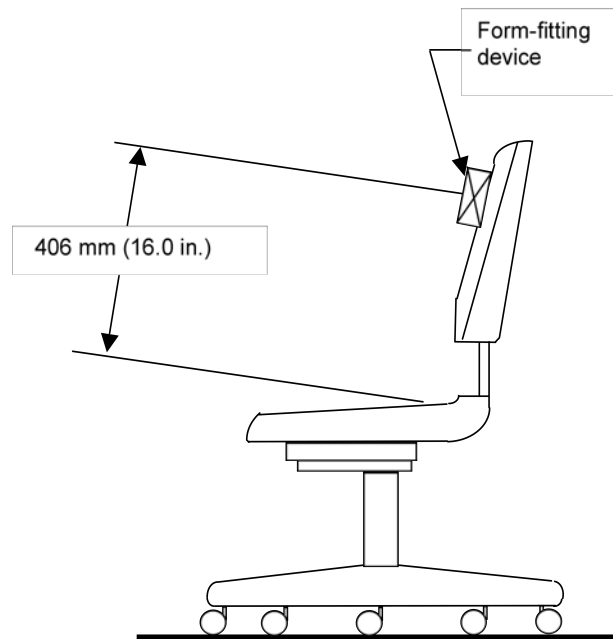

**Figure 5b - Positioning of Form-Fitting Device for Backrests Higher than 452 mm
(17.8 in.) Backrest Strength Test - Static - Type I**

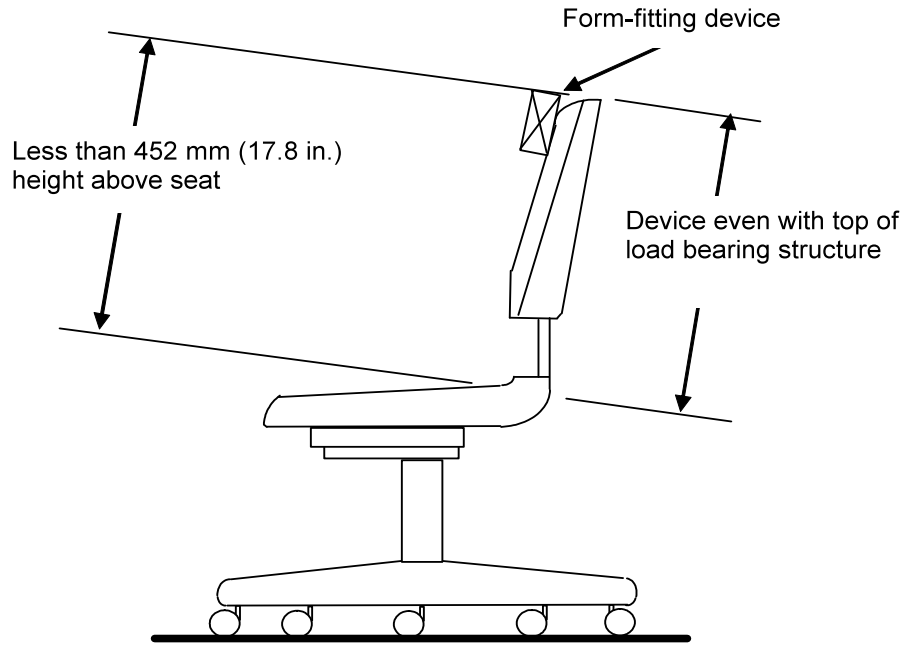

Figure 5c - Positioning of Form-Fitting Device for Backrests Lower than 452 mm (17.8 in.) Backrest Strength Test - Static - Type I

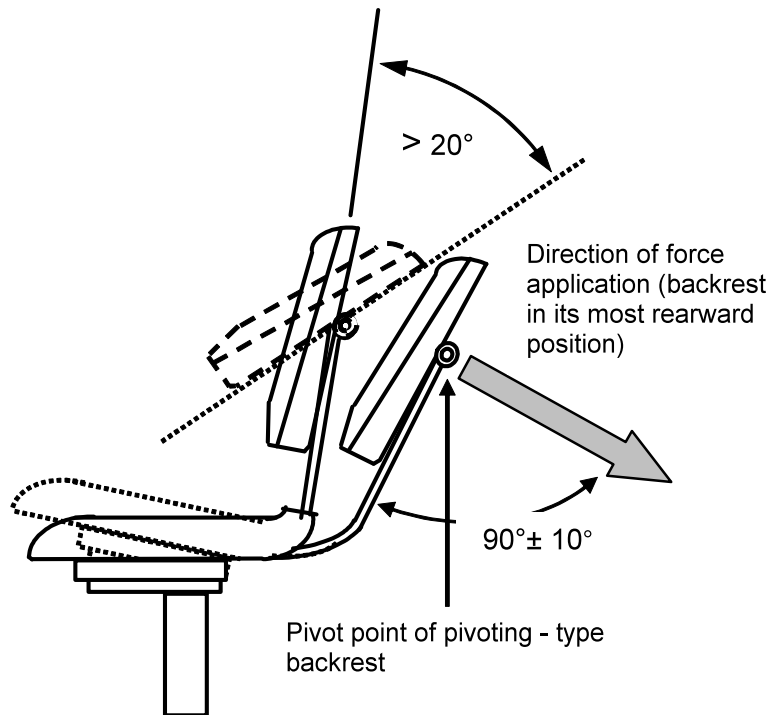
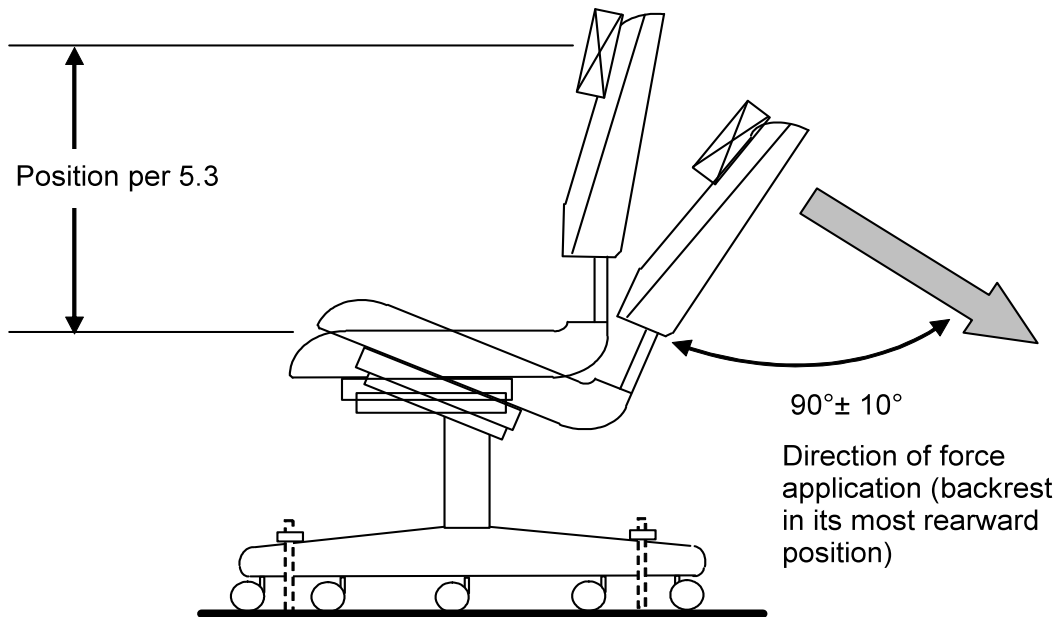

Figure 5d - Force Application for Backrests that Pivot Greater than 20° Backrest Strength Test - Static - Type I



**Figure 5e - Force Application for All Other Backrests
Backrest Strength Test - Static - Type I**

5 Backrest Strength Test - Static - Type I (See Figures 5a through 5e)

5.1 Applicability

This backrest strength test shall be performed on Type I chairs. For chairs with tilt locks, locking the chair changes the chair type (See Section 4) and must also be tested according to Section 6 in the upright locked position. An additional chair may be used for the Section 6 testing.

Note: This test does not apply to chairs with backrest height less than 200 mm (7.9 in.).

5.2 Purpose of Test

The purpose of this test is to evaluate the ability of the chair to withstand stresses such as those caused by the user exerting a rearward force on the backrest of the chair.

5.3 Test Setup

5.3.1 The chair shall be placed on a test platform in an upright position and the base shall be restrained from movement, but shall not restrict movement of the backrest or arms of the chair. Figure 5e shows one acceptable method of restraining the chair.

5.3.2 If adjustable features are available, all adjustments shall be set at normal use conditions, except for height-adjustable pivoting backrests which shall have the pivot point set at its maximum height or 406 mm (16.0 in.) whichever is less.

5.3.3 After making the above adjustments, determine points 406 mm (16 in.) and 452 mm (17.8 in.) above the seat. (See Figure 5a and Section 3.5). Mark these points on the vertical centerline of the backrest.

- a) If the top of the load-bearing structure/surface of the backrest is greater than or equal to 452 mm (17.8 in.) above the seat, position the center of the form-fitting device (See Definition 2.9) 406 mm (16 in.) above the seat. (See Figure 5b).
- b) If the top of the load-bearing structure/surface of the backrest is less than 452 mm (17.8 in.) above the seat, position the top of the form-fitting device even with the top of the load-bearing structure/surface. (See Figure 5c).
- c) If the unit has a pivoting backrest that stops at a position less than or equal to 20 degrees rearward (See Figure 5d), position the form-fitting device as directed in a) or b). If the unit has a pivoting backrest that stops at a position greater than 20 degrees rearward of the backrest, position the center of the form-fitting device at the height of the pivoting point. (See Figure 5d).

5.3.4 Attach a loading device (front push or back pull) to the horizontal center of the backrest as determined above. With the backrest at its back stop position, apply a force that is initially 90 degrees \pm 10 degrees to the plane of the backrest. (See Figure 5e). The force is not intended to be maintained at 90 degrees \pm 10 degrees throughout the loading of the backrest. If applying the load with a cable and pulley system, the cable must initially be a minimum of 762 mm (30 in.) in length from the attachment point to the pulley.

Note: Where the design of the chair does not allow the transfer of force(s) from the form-fitting device to the load-bearing structure/surface, then a bridging device 38 mm to 102 mm (1.5 in. to 4 in.) in height may be used to span the width of the load-bearing structure/surface. The plane of the backrest may be defined by the front of the CMD upright.

5.4 Test Procedures

5.4.1 Functional Load

- a) A force of 890 N (200 lbf.) shall be applied to the backrest at the backstop position for one (1) minute. If the backrest/tilt lock mechanism will not accept the load due to gradual slipping of the adjustment mechanism during the load application, set the backrest to its most rearward (stopped) position, then apply the specified load(s).
- b) Remove the load.

5.4.2 Proof Load

- a) A force of 1334 N (300 lbf.) shall be applied to the backrest at the backstop position for one (1) minute. If the backrest/tilt lock mechanism will not accept the load due to gradual slipping of the adjustment mechanism during the load application, set the backrest to its most rearward (stopped) position, then apply the specified load(s).
- b) Remove the load.

5.5 Acceptance Level

5.5.1 Functional Load

There shall be no loss of serviceability to the chair.

5.5.2 Proof Load

There shall be no sudden and major change in the structural integrity of the chair. Loss of serviceability is acceptable.

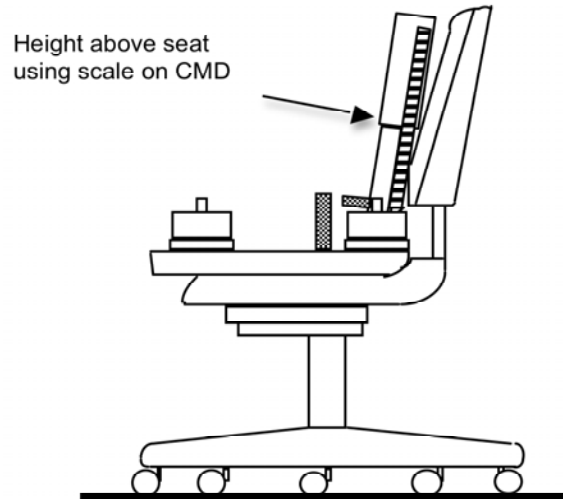

**Figure 6a - Height Determination
Backrest Strength Test - Static - Type II and III**

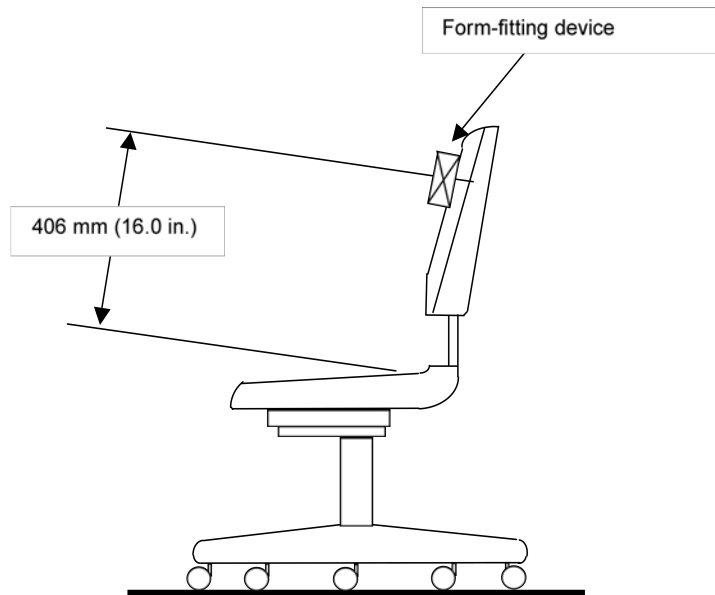

**Figure 6b - Positioning of Form-Fitting Device for Backrests Higher than 452 mm
(17.8 in.) Backrest Strength Test - Static - Type II and III**

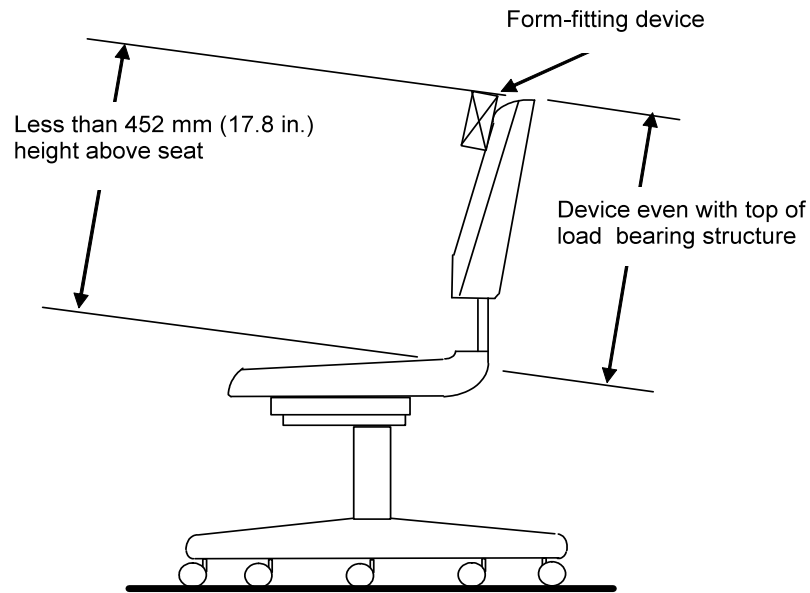

Figure 6c - Positioning of Form-Fitting Device for Backrests Lower than 452 mm (17.8 in.) Backrest Strength Test – Static - Type II and III

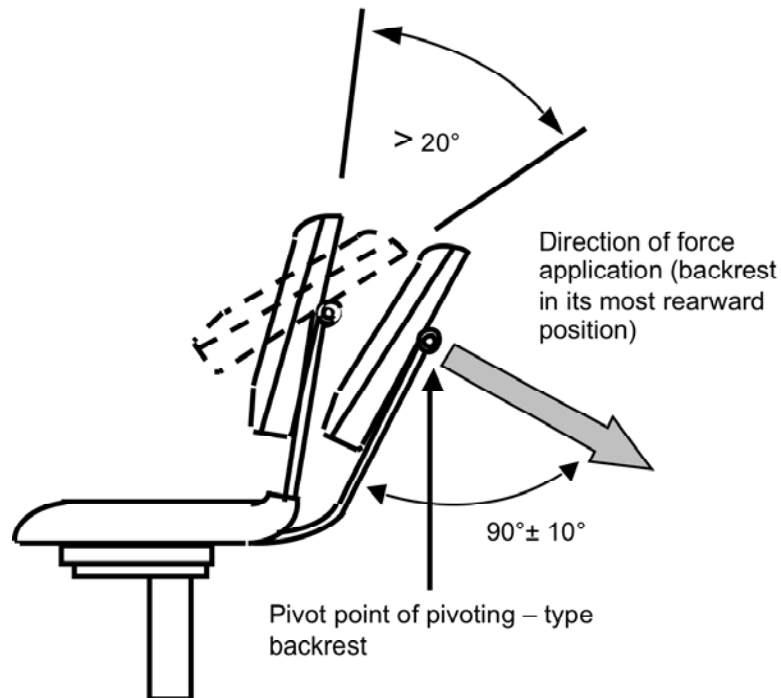
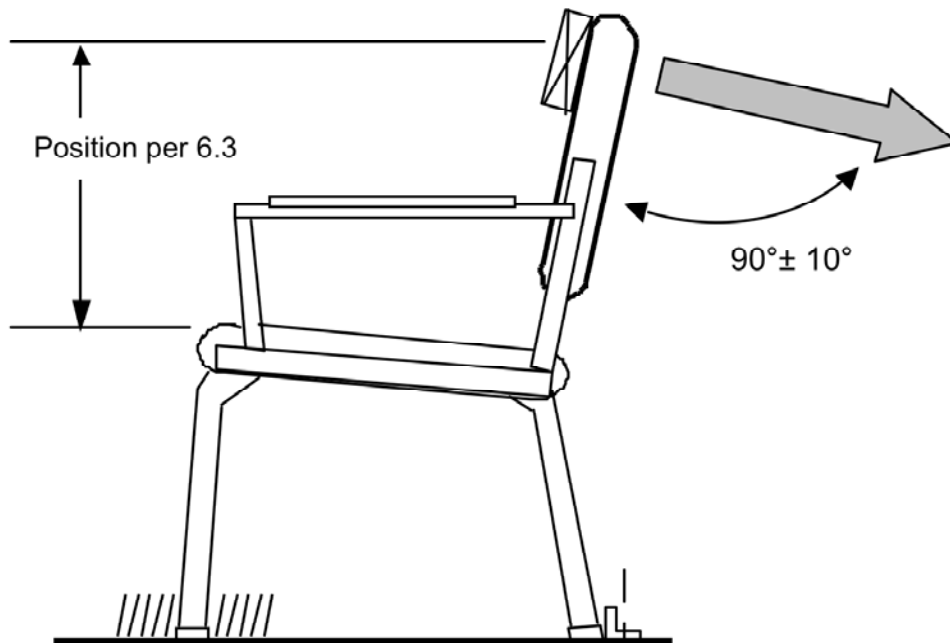
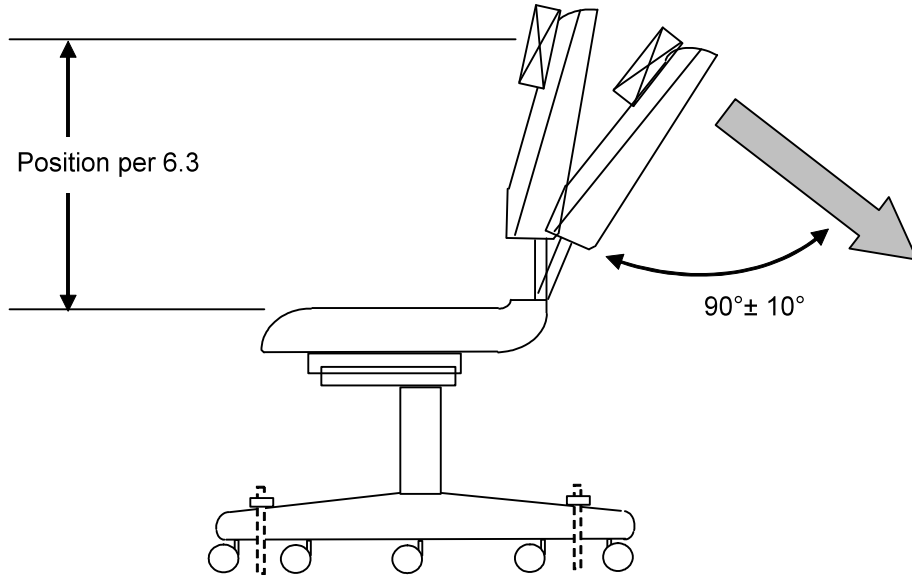

Figure 6d - Force Application for Backrests that Pivot Greater than 20° Backrest Strength Test - Static - Type II and III



**Figure 6e - Force Application for All Other Backrests
Backrest Strength Test - Static - Type II and III**

6 Backrest Strength Test - Static - Type II & III (See Figures 6a through 6e)

6.1 Applicability

This backrest strength test shall be performed on Type II and III chairs.

Note: This test does not apply to chairs with backrest height less than 200 mm (7.9 in.).

6.2 Purpose of Test

The purpose of this test is to evaluate the ability of the chair to withstand stresses such as those caused by the user exerting a rearward force on the backrest of the chair.

6.3 Test Setup

6.3.1 The chair shall be placed on a test platform in an upright position and the base shall be restrained from movement, but shall not restrict movement of the backrest or arms of the chair. Figure 6e shows one acceptable method of restraining the chair.

6.3.2 If adjustable features are available, all adjustments shall be set at normal use conditions, except for height-adjustable pivoting backrests which shall have the pivot point set at its maximum height or 406 mm (16.0 in.) whichever is less.

6.3.3 After making the above adjustments, determine points 406 mm (16 in.) and 452 mm (17.8 in.) above the seat. (See Figure 6a and Section 3.5). Mark these points on the vertical centerline of the backrest.

- a) If the top of the load-bearing structure/surface of the backrest is greater than or equal to 452 mm (17.8 in.) above the seat, position the center of the form-fitting device (See Definition 2.9) 406 mm (16 in.) above the seat. (See Figure 6b).
- b) If the top of the load-bearing structure/surface of the backrest is less than 452 mm (17.8 in.) above the seat, position the top of the form-fitting device even with the top of the load-bearing structure/surface. (See Figure 6c).
- c) If the unit has a pivoting backrest that stops at a position less than or equal to 20 degrees rearward (See Figure 6d), position the form-fitting device as directed in a) or b). If the unit has a pivoting backrest that stops at a position greater than 20 degrees rearward of the backrest, position the center of the form-fitting device at the height of the pivoting point. (See Figure 6d).

6.3.4 Attach a loading device (front push or back pull) to the horizontal center of the backrest as determined above. With the backrest at its back stop position, apply a force that is initially 90 degrees \pm 10 degrees to the plane of the backrest (see Figure 6e). The force is not intended to be maintained at 90 \pm 10 degrees throughout the loading of the backrest. If applying the load with a cable and pulley system, the cable must initially be a minimum of 762 mm (30 in.) in length from the attachment point to the pulley. For backrests with complex or varying contours, the plane of the backrest may be defined by the front of the CMD upright.

Note: Where the design of the chair does not allow the transfer of force(s) from the form-fitting device to the load-bearing structure/surface, then a bridging device 38 mm to 102 mm (1.5 in. to 4 in.) in height may be used to span the width of the load-bearing structure/surface. The plane of the backrest may be defined by the front of the CMD upright.

6.4 Test Procedures

6.4.1 Functional Load

- a) A force of 667 N (150 lbf.) shall be applied to the backrest at the backstop position for one (1) minute. If the backrest/tilt lock mechanism will not accept the load due to gradual slipping of the adjustment mechanism during the load application, set the backrest to its most rearward (stopped) position, then apply the specified load(s).
- b) Remove the load.

6.4.2 Proof Load

- a) A force of 1112 N (250 lbf.) shall be applied to the backrest at the backstop position for one (1) minute. If the backrest/tilt lock mechanism will not accept the load due to gradual slipping of the adjustment mechanism during the load application, set the backrest to its most rearward (stopped) position, then apply the specified load(s).
- b) Remove the load.

6.5 Acceptance Level

6.5.1 Functional Load

A functional load applied once shall cause no loss of serviceability to the chair.

6.5.2 Proof Load

A proof load applied once shall cause no sudden and major change in the structural integrity of the chair. Loss of serviceability is acceptable.

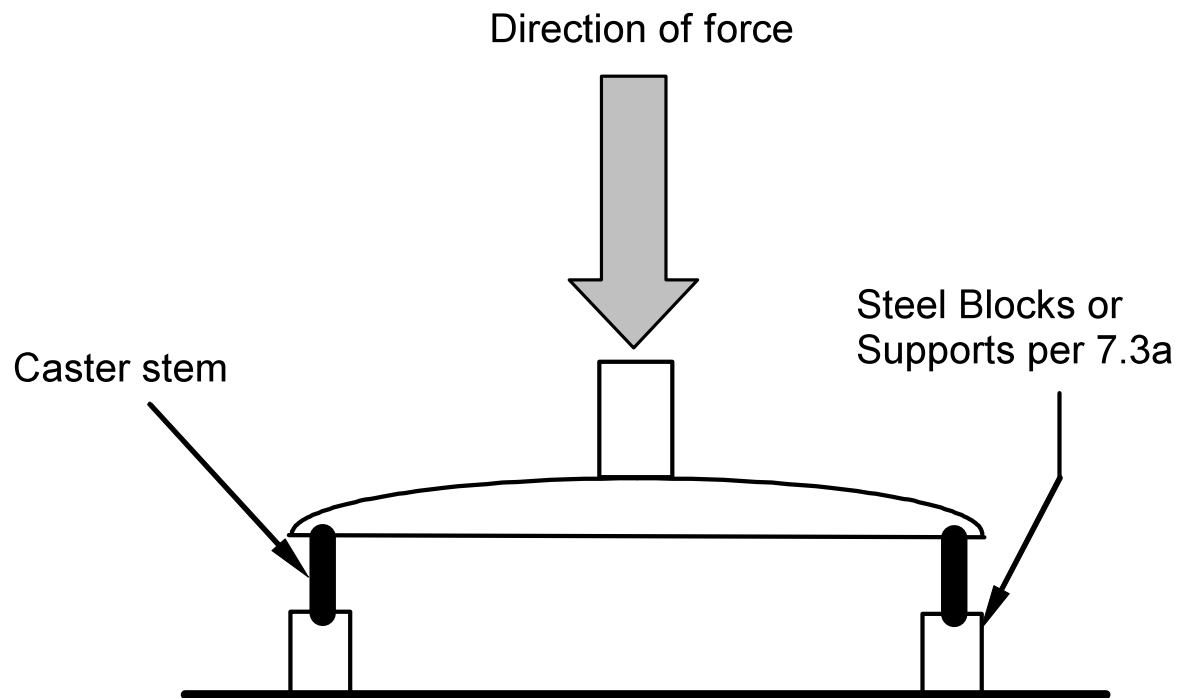

Figure 7 - Base Test - Static

7 Base Test - Static (See Figure 7)

7.1 Applicability

The test shall be performed on all pedestal bases.

7.2 Purpose of Test

The purpose of this test is to evaluate the ability of a pedestal base to withstand excessive vertical forces.

7.3 Test Setup

- a) Remove the casters or glide foot (caster/glide stems shall remain in place). Caster/glide stems are required for support. If caster/glide stems are not available, a suitable fixture may be used to simulate the stem. Place the stems on support blocks as shown in Figure 7. The blocks or supports shall be of sufficient height to prevent the center column and/or legs from touching the test platform during the test. If the base has glides with a non-removable stem, the glides shall remain in place and be placed on blocks or supports. Remove the seat support mechanism(s) and height adjustment mechanism (if applicable) from the base. Apply the load to the vertical support column, or test fixture that simulates the taper/base interface.
- b) The base legs shall be allowed to move laterally and the center of the base to move vertically as the force is applied. The blocks or supports shall support the base in a manner and location similar to the original casters/glides and shall not impede the deflection and/or lateral motion during the test. Blocks or supports shall not lessen the severity of the test.

7.4 Test Procedures

- a) A force of 11,120 N (2500 lbf.) shall be applied for one (1) minute.
- b) Remove the force.
- c) Apply a second force of 11,120 N (2500 lbf.) for one (1) minute.
- d) Remove the load.

7.5 Acceptance Level

There shall be no sudden and major change in the structural integrity of the base. The center column may not touch the test platform during the load applications.

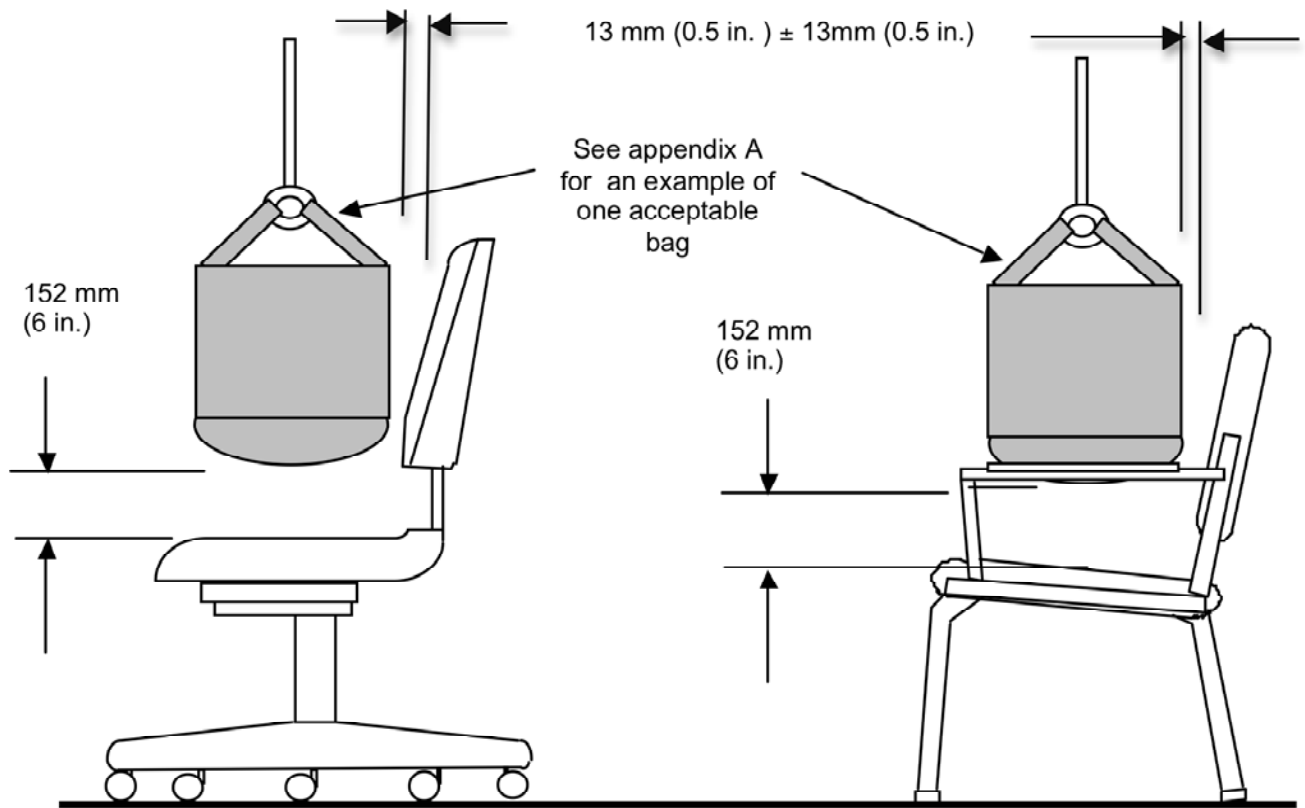

Figure 8 - Drop Test - Dynamic

8 Drop Test - Dynamic (See Figure 8)

8.1 Applicability

This test applies to all chair types.

8.2 Purpose of Test

The purpose of this test is to evaluate the ability of the chair to withstand heavy and abusive impact forces on the seat.

8.3 Test Setup

- a) The unit shall be placed on a test platform.
- b) For chairs with a seat height adjustment feature, set the adjustment to its highest position. For chairs with glides that adjust greater than 50 mm (2.0 in), set them at 13 mm (0.5 in.) from their highest position. If other adjustable features are available, set these adjustments at normal use conditions. Casters, if present, shall be initially placed at the apparent worst-case position (typically at a position 90 degrees to the base leg).
Note: For chairs with lockable seat angles, the seat shall be tested in the unlocked position.
- c) A test bag containing sand and/or shot shall be attached to a device permitting a free fall to the seating position as shown in Figure 8.
- d) The bag shall be centered side-to-side on the seat and shall be positioned 13 mm (0.5 in.) \pm 13 mm (0.5 in.) from the most forward surface of the backrest during free fall. The bag shall not contact the backrest during the free fall.

8.4 Test Procedures

8.4.1 Functional Load Test

- a) A test bag weighing 102 kg (225 lb.) shall be raised 152 mm (6 in.) above the uncompressed seat and released one time. (See Figure 8).
- b) Remove the bag.
- c) For chairs with seat height adjustment features, set height to its lowest position and repeat a) and b).

8.4.2 Proof Load Test

- a) Repeat setup in 8.3 and increase the weight of the test bag to a proof load of 136 kg (300 lb.).
- b) The test bag shall be raised 152 mm (6 in.) above the uncompressed seat and released one time. (See Figure 8).
- c) Remove the bag.
- d) For chairs with height adjustments, set seat height to its lowest position and repeat a) through c). A second chair may be used for testing the chair in the lowest position

Note: If a second chair is used for the proof load test, it must also be subjected to the functional load impact per Section 8.4.1 while in its lowest position.

8.5 Acceptance Level

8.5.1 Functional Load

There shall be no loss of serviceability.

8.5.2 Proof Load

There shall be no sudden and major change in the structural integrity of the chair. Loss of serviceability is acceptable.

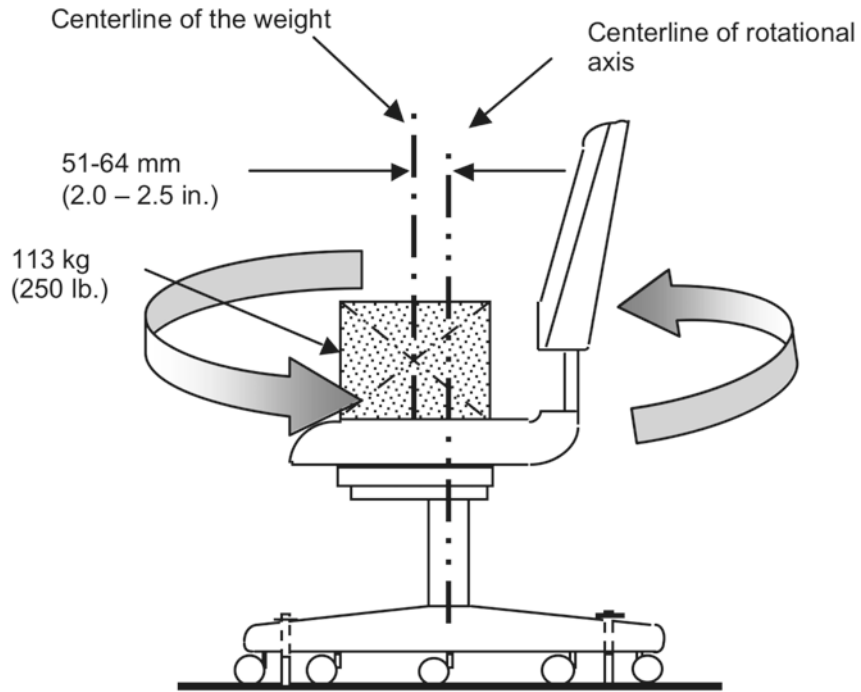

Figure 9 - Swivel Test - Cyclic

9 Swivel Test - Cyclic (See Figure 9)

9.1 Applicability

This test applies to all chair types with a swivel seat.

9.2 Purpose of Test

The purpose of this test is to evaluate the ability of the chair to withstand stresses and wear of repeated swiveling.

9.3 Test Setup

- a) The chair shall be restrained on a platform. Either the seat or the platform shall be restrained from rotation. Figure 9 shows one acceptable method of restraint.
- b) If the seat height is adjustable, set it to the maximum seat height position. Set all other adjustable features to the normal use condition.
- c) A 113 kg (250 lb.) load shall be placed on the seat such that the center of gravity of the load is 51 to 64 mm (2 to 2.5 in.) forward of the centerline of the rotational axis as shown in Figure 9.
- d) The cycling device shall be adjusted to rotate the lesser of the following: the available range of rotation or 360 degrees \pm 10 degrees. If the available range of rotation is less than 360 degrees, the rotation of the test machine shall be adjusted such that the swivel mechanism touches but does not override the stops. The rotation may be either bi-directional (alternating) or unidirectional.
- e) For chairs that swivel 360 degrees, a cycle is one full rotation. For chairs that swivel less than 360 degrees, one cycle is rotating from one stop to the other stop.

9.4 Test Procedure

- a) The seat or platform shall rotate for 60,000 cycles at a rate between 5 and 15 rotations per minute.
- b) If the seat height is adjustable set the height to its lowest position.
- c) For all chairs, continue the test for an additional 60,000 cycles to a total of 120,000 cycles.

9.5 Acceptance Level

There shall be no loss of serviceability.

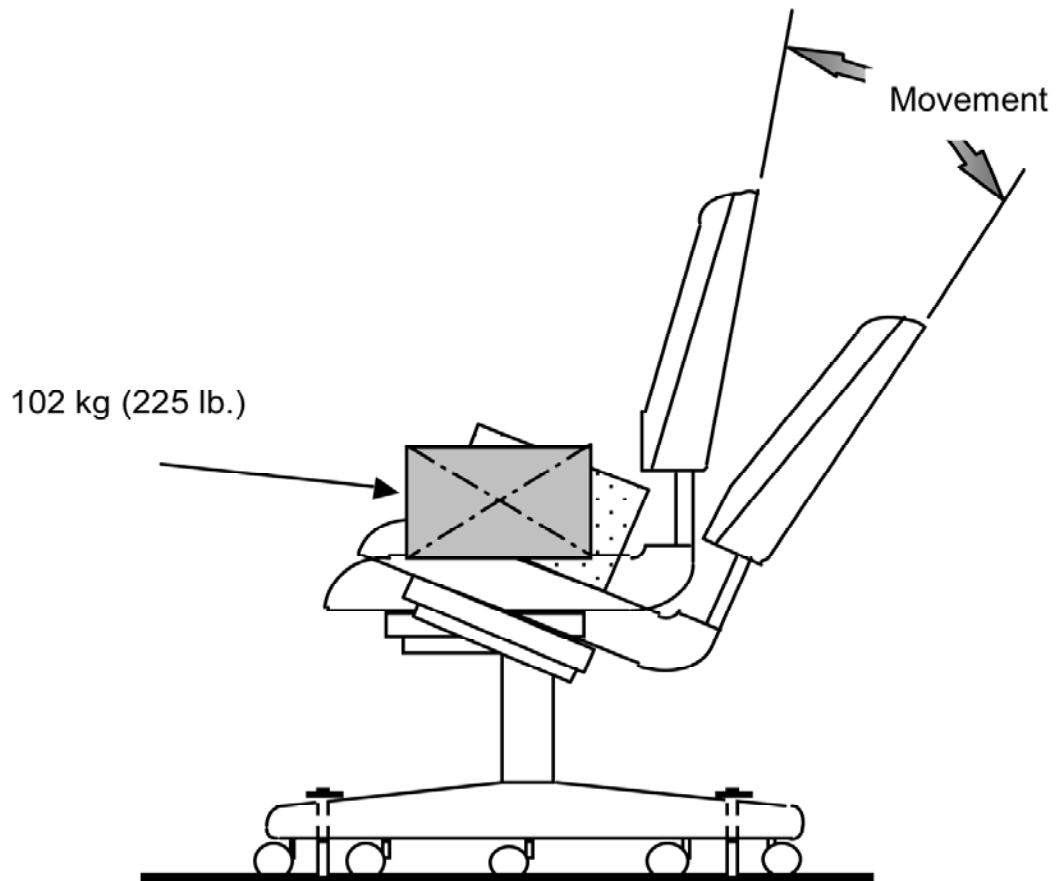

Figure 10 - Tilt Mechanism Test - Cyclic

10 Tilt Mechanism Test - Cyclic (See Figure 10)

10.1 Applicability

This test shall be performed on Type I and Type II chairs with tilting backrests.

10.2 Purpose of Test

The purpose of this test is to evaluate the ability of the tilt mechanism to withstand the fatigue stresses and wear caused by repeated tilting.

10.3 Test Setup

- a) The chair or fixture with attached tilt mechanism shall be restrained on a test platform. Figure 10 shows one acceptable method of restraint.
- b) If adjustable features are available, all adjustments shall be set at normal use conditions.
- c) A cycling device shall be attached to the chair or fixture at any location appropriate to apply a controlled (push and/or pull) motion.
- d) A test load of 102 kg (225 lb.) shall be secured on the center of the seat (or equivalent location on the fixture).
- e) Adjust the cycling device to move the mechanism between the front and back stops, without overriding or impacting either stop.

10.4 Test Procedure

The unit shall be cycled for 300,000 cycles at a rate between 10 and 30 cycles per minute. The tilt mechanism and/or cycling device should be checked and readjusted as needed to maintain the original conditions specified.

10.5 Acceptance Level

There shall be no loss of serviceability to the tilt mechanism.

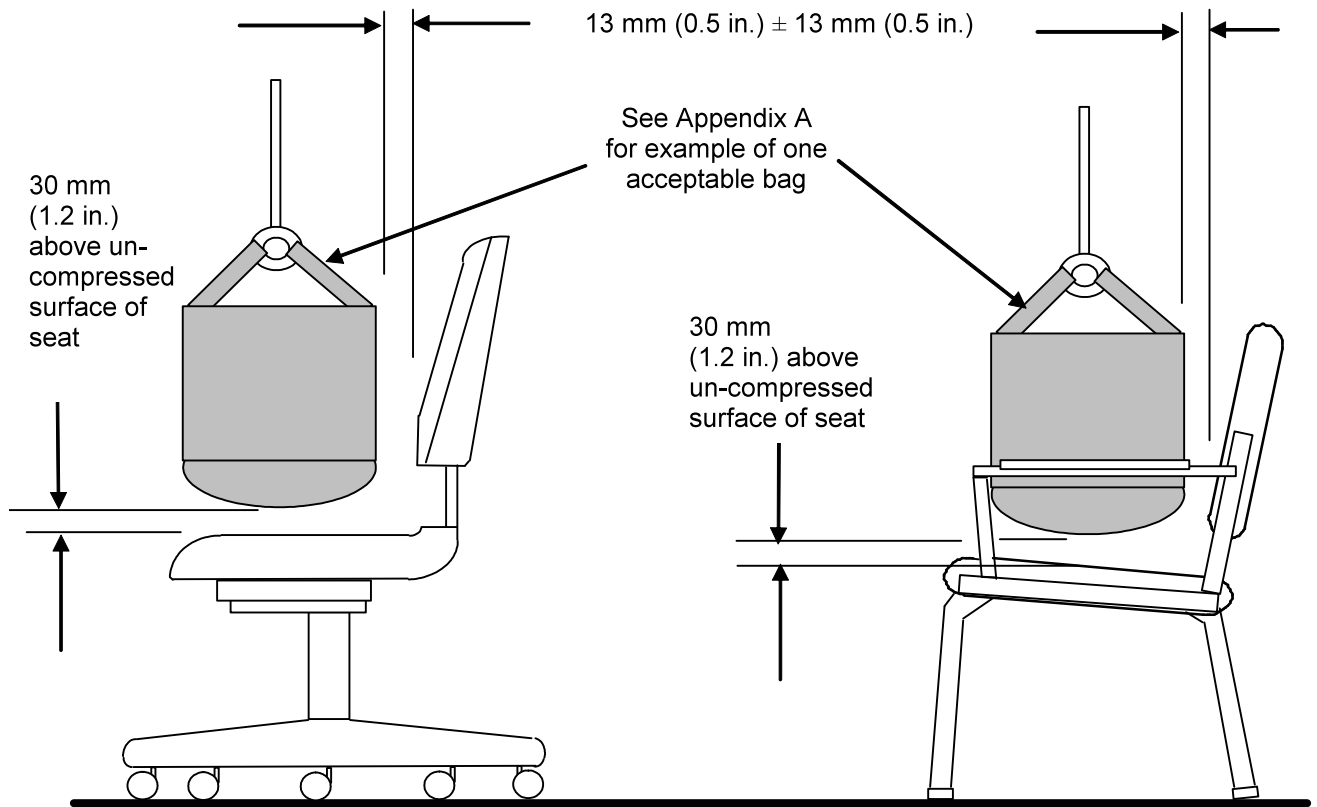

Figure 11a - Seating Durability Test - Cyclic

11 Seating Durability Tests – Cyclic (See Figure 11a and 11b)

Note: This is a two-part test. The impact test and front corner load-ease tests must be run sequentially for this evaluation.

11.1 Applicability

These tests apply to all chair types.

11.2 Purpose of Tests

The purpose of these tests is to evaluate the ability of chairs to withstand fatigue stresses and wear caused by downward vertical force(s) on the seat.

11.3 Impact Test**11.3.1 Test Setup**

- a) The unit shall be placed on a test platform and be restrained in a manner that will maintain the impact location on the seat. The method of restraint shall not add support or structure to the chair, or inhibit movement of the chair response to the impact. Casters, if present, shall be initially placed at the apparent worst-case position (typically at a position 90 degrees to the base leg).
- b) If adjustable features are available, all adjustments shall be set at normal use conditions.
- c) Chairs with less than 44 mm (1.75 in.) of cushioning materials in the seat shall have foam added to bring total cushioning thickness to 50 mm \pm 6 mm (2 in. \pm 0.25 in.). Any additional foam added to the top of the seat shall have a 25% Indentation Force Deflection (IFD) of 200 N \pm 22 N (45 lbf. \pm 5 lbf.).¹

Note: Flexible seat surfaces (i.e., mesh, flexible plastic, etc.) are not considered cushioning materials.

- d) A test bag weighing 57 kg (125 lb.) shall be attached to a cycling device, permitting a free fall to the seat as shown in Figure 11a. The free fall shall begin after lifting the test bag 30 mm (1.2 in.) above the uncompressed surface on the seat, as measured at the center of the seat. The drop height and/or seat height shall be adjusted during the test if the drop height changes by more than 13 mm (0.5 in.). The cycling device shall be set at a rate between 10 and 30 cycles per minute.
- e) The bag shall be centered side-to-side on the seat and shall be 13 mm (0.5 in.) \pm 13 mm (0.5 in.) from the most forward surface of the backrest during free fall. The bag shall not contact the backrest during the free fall.

11.3.2 Test Procedure

The chair shall be tested to 100,000 cycles.

¹ Specimen thickness 102 mm (4 in.). See Method B₁, Indentation Force Deflection Test, in *Standard Test Methods for Flexible Cellular Materials —Slab, Bonded, and Molded Urethane Foams*, ASTM D 3574-01.

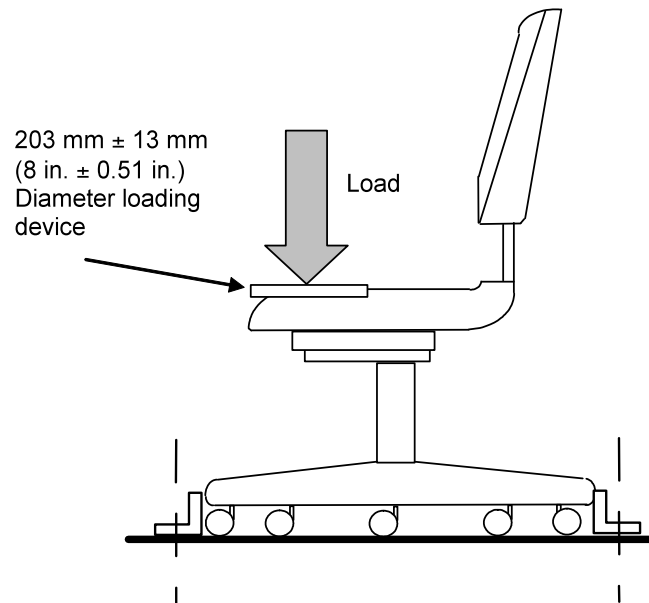
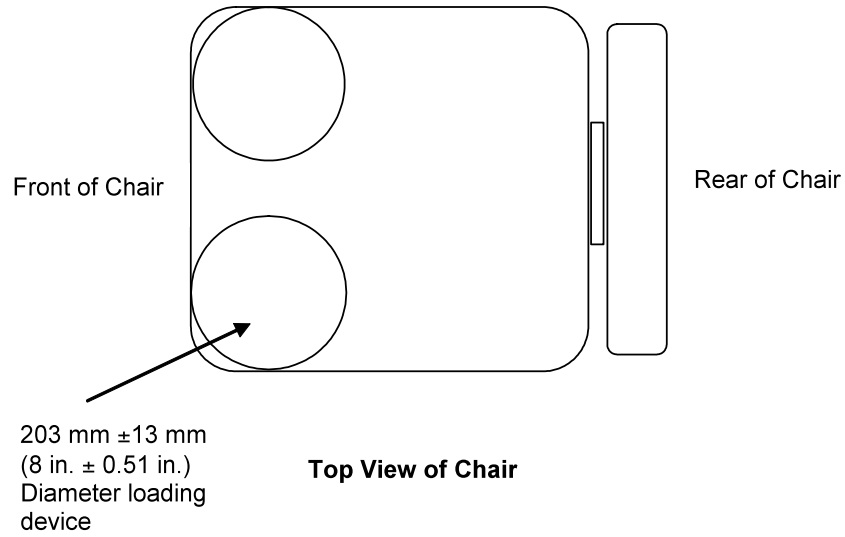

Figure 11b - Front Corner Load-Ease Test - Cyclic - Off-center

11.4 Front Corner Load-Ease Test – Cyclic – Off-center

11.4.1 Test Setup

After completing the impact test in Section 11.3, apply a load of 734 N (165 lbf.) through a 203 mm \pm 13 mm (8 in. \pm 0.51 in.) diameter loading device at one front corner flush to each structural edge. If arms interfere with the placement of the weights and are intended to be removable, they shall be removed for this test. If arms interfere but are not removable (or adjustable) the load shall be positioned to avoid interference. If cushion material was used during impact testing (11.3.1c) it may remain in place during this testing to avoid uneven/point loading of the seat.

11.4.2 Test Procedure

Raise the loading device from the seat and lower completely, without impact to the seat so that it takes the entire load without any support from the cycling device, at a rate of 10 to 30 cycles per minute. Test for 20,000 cycles. Reposition the load to the other front corner, and perform the test for an additional 20,000 cycles.

Note: Applying the loads in an alternating sequence to attain a total of 40,000 cycles is an acceptable method of performing this test.

11.5 Acceptance Level

There shall be no loss of serviceability to the chair after completion of both the impact and load-ease tests.

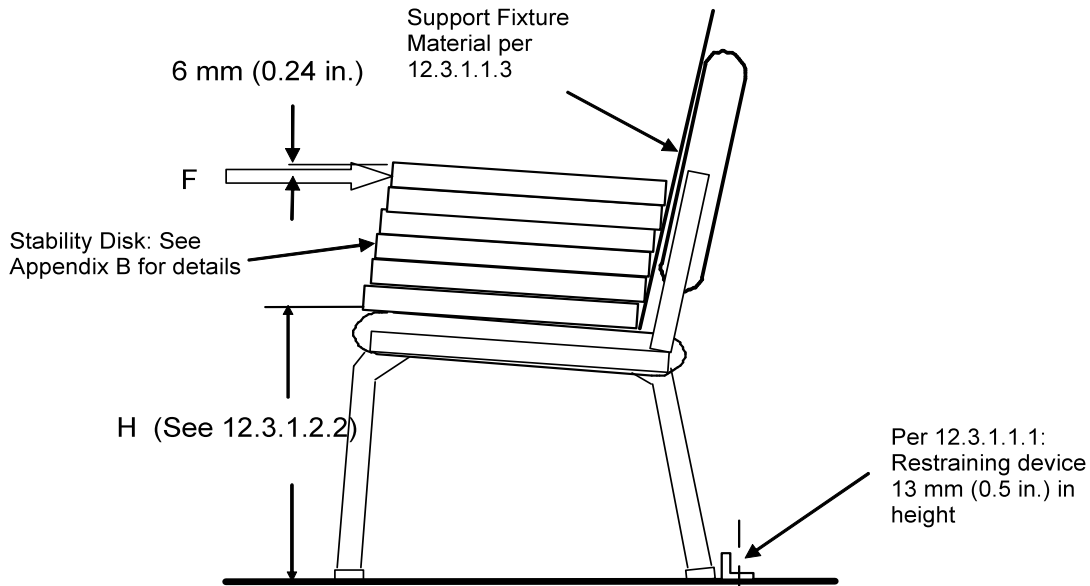

Figure 12a - Rear Stability Test for Type III Chairs

12 Stability Tests

12.1 Applicability

The stability tests shall be performed on all types of chairs.

Note: Rearward stability tests apply only to chairs with backrests greater than 200 mm (7.9 in.) in height as measured with the BIFMA CMD.

12.2 Purpose of Tests

The purpose of these tests is to evaluate the front and rear stability of chairs.

12.3 Rear Stability

12.3.1 Rear Stability Test for Type III Chairs (Figure 12a)

Note: If a chair needs to be tested as more than one type, it is recommended that it be tested in the sequence given. If tested out of sequence (or individually by type) all weights must be entirely removed from the chair before starting each test.

12.3.1.1 Test Setup

12.3.1.1.1 The chair shall be placed on a test platform. A block, obstruction or other restraining device 13 mm (0.5 in.) in height shall be affixed to the test platform. The device shall prevent sliding but not restrict the unit from tipping. For chairs that have rotating seats, the base and casters shall be positioned to offer the least resistance to rearward tipping of the chair.

- 12.3.1.1.2** For chairs with adjustable features, all adjustments shall be set at the apparent least stable condition for rearward stability, such as:
- maximum height of seat or backrest, or both,
 - rearmost seat or backrest position, or both,
 - the least stable condition of casters or glides.

Note: For chairs with tilt locks, locking the mechanism in the near upright position changes the chair type (See Section 4: Chair Type) and the chair shall be tested in the locked (near upright) condition and in the unlocked (reclined) condition as per Section 12.3.2.

- 12.3.1.1.3** Place a support fixture made of a $1.5 \text{ mm} \pm 0.4 \text{ mm}$ ($0.060 \text{ in.} \pm 0.015 \text{ in.}$) thick polypropylene, 356 mm (14 in.) wide and 711 mm (28 in.) tall against the chair back so that it approximates the contour of the back.

12.3.1.2 Test Procedure

- 12.3.1.2.1** Load the chair with 6 disks (See Appendix B). Place the first disk on the seat so it touches the support fixture. As each disk is added to the stack slide it along the lower disk until it contacts the support fixture as shown in Figure 12a. As each disk is added, the backrest may move such that the lower disks do not remain against the support fixture; this is acceptable, do not reposition the disks.

- 12.3.1.2.2** Apply a horizontal force to the highest disk. The location of the force application is 6 mm (0.25 in.) from the top of the disk. (See Figure 12a)

For chairs with seat height (as measured at the front of the bottom of the lowest disk when all disks are in the chair) less than 710 mm (28.0 in.), calculate the force as follows:

- $F = 0.1964 (1195 - H)$ Newton. H is the seat height in mm.
- $[F = 1.1 (47 - H)$ pounds force.]. H is the seat height in inches.

For chairs with seat height equal to or greater than 710 mm (28.0 in.), a fixed force of 93 N (20.9 lbf.) shall be applied.

12.3.1.3 Acceptance level

The chair shall not tip over.

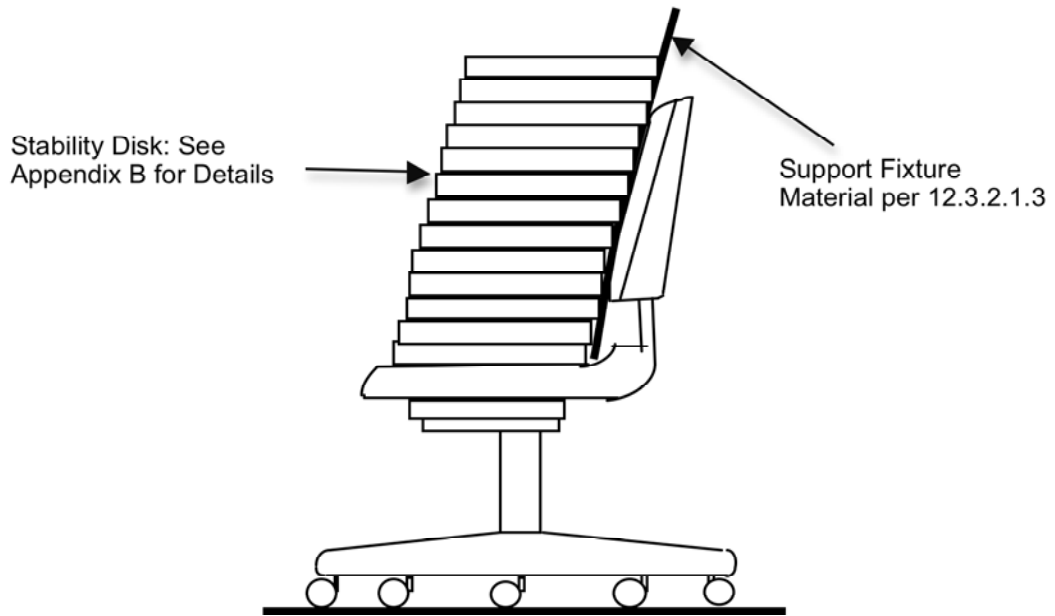

Figure 12b - Rear Stability Test for Type I and II Chairs

12.3.2 Rear Stability Test for Type I and II Chairs (Figure 12b)

Note: For chairs with tilt locks, locking the chair changes the chair type (See Section 4) and must also be tested according to Section 12.3.1 in the upright locked position.

12.3.2.1 Test Setup

12.3.2.1.1 The chair shall be placed on a test platform. A block, obstruction or other restraining device 13 mm (0.5 in.) in height shall be affixed to the test platform. The device shall prevent sliding but not restrict the unit from tipping. On chairs that rotate, the base and casters shall be positioned to offer the least resistance to rearward tipping of the chair.

12.3.2.1.2 On chairs with adjustable features, all adjustments shall be set at the apparent least stable condition for rearward stability, such as:

- a) maximum height of seat or backrest, or both,
- b) minimum tension of tilt mechanism,
- c) rearmost seat or backrest position, or both,
- d) the least stable condition of casters or glides.

12.3.2.1.3 Place a support fixture made of a 1.5 mm \pm 0.4 mm (0.060 in. \pm 0.015 in.) thick polypropylene, 356 mm (14 in.) wide and 711 mm (28 in.) tall against the chair back so that it approximates the contour of the back.

12.3.2.2 Test Procedure

12.3.2.2.1 Load the chair with 13 disks (See Appendix B). Place the first disk on the seat so it touches the support fixture. As each disk is added to the stack slide it along the lower disk until it contacts the support fixture as shown in Figure 12b. As each disk is added, the backrest may move such that the lower disks do not remain against the support fixture; this is acceptable, do not reposition the disks.

If the chair does not tip over and the tilt mechanism does not tilt to its most rearward position (i.e., at its tilt stop) when the disks are placed in the chair, the chair shall also be tested according to 12.3.1 with the chair in the unlocked position.

12.3.2.3 Acceptance level

The chair shall not tip over.

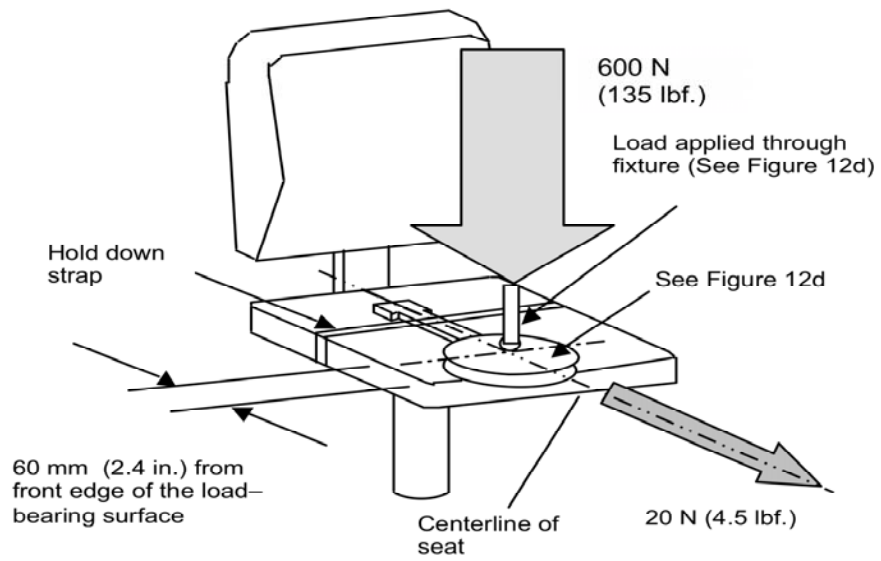

Figure 12c - Front Stability Test

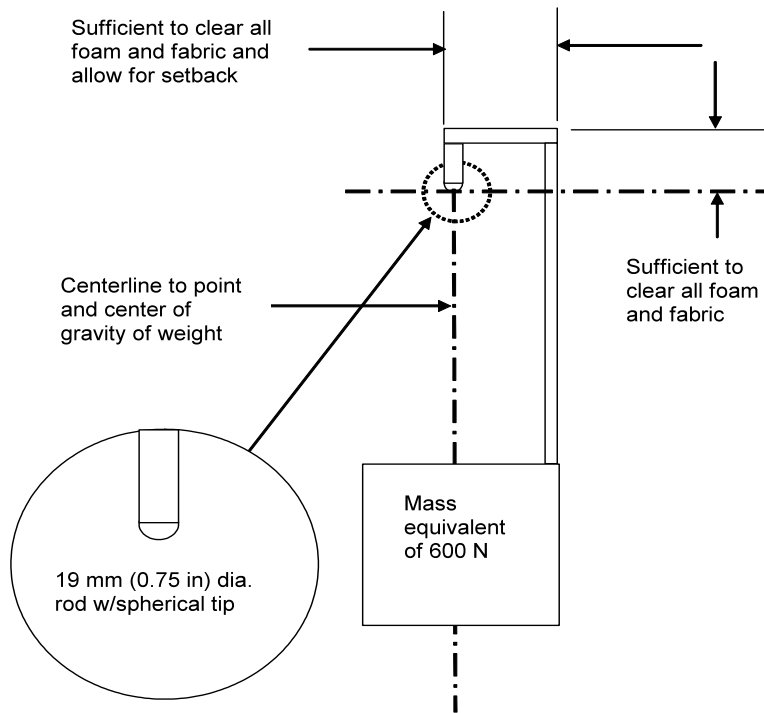

Figure 12d - Front Stability Loading Fixture

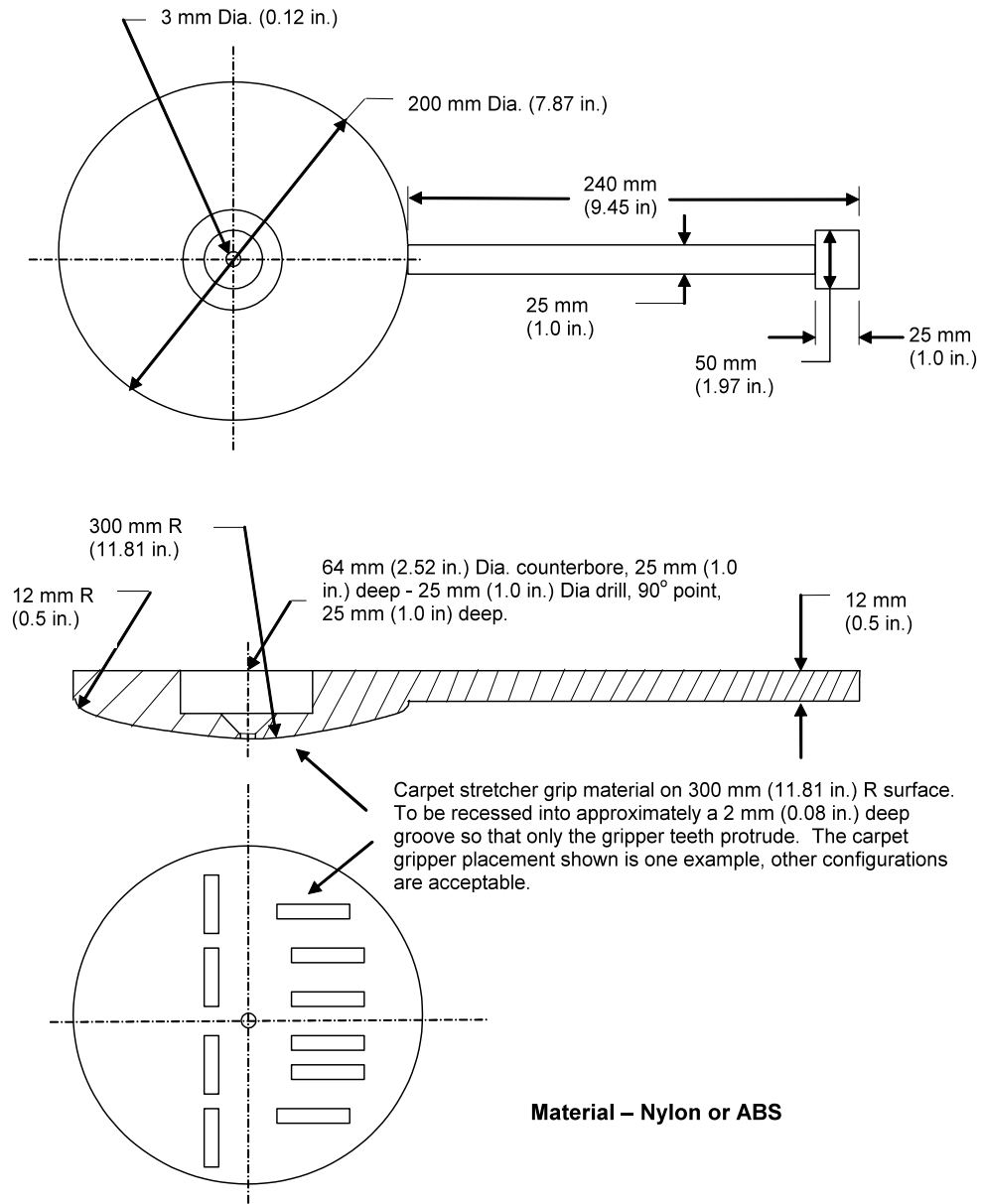

Figure 12e - Front Stability Loading Disk

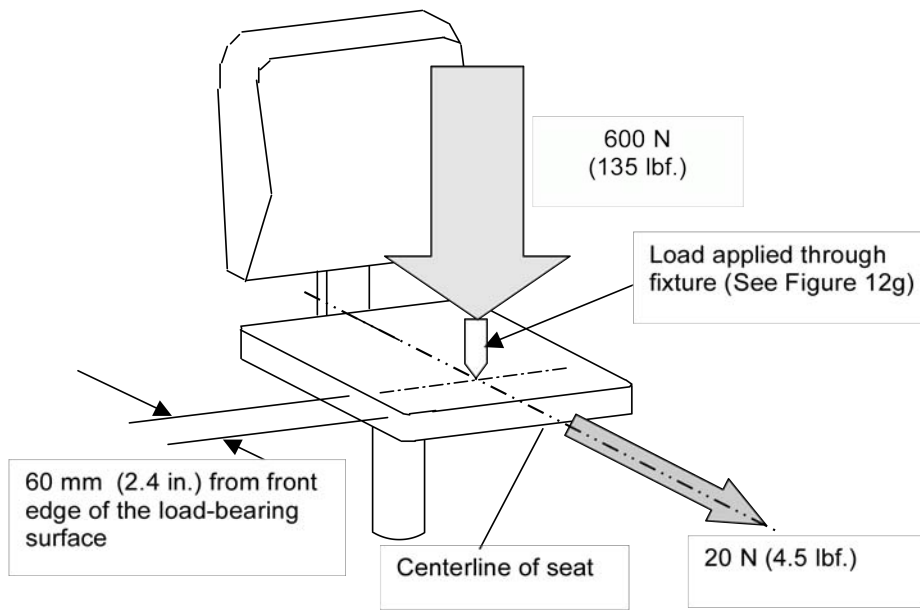

Figure 12f - Front Stability Test

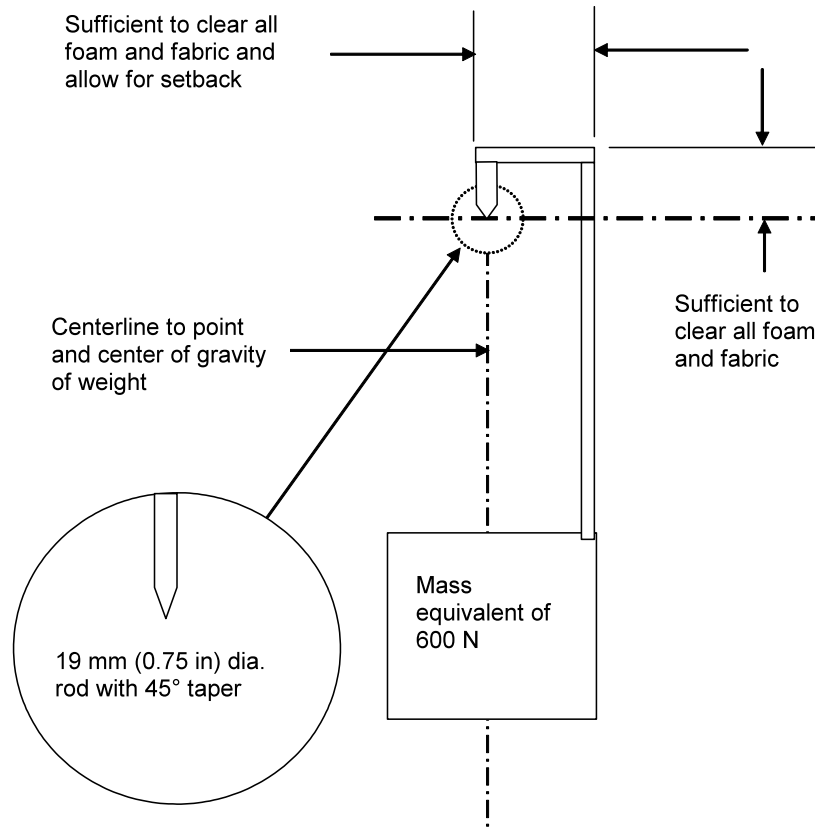

Figure 12g - Front Stability Loading Fixture

12.4 Front Stability

Front stability shall be determined by either the method described in Sections 12.4.1 and 12.4.2 or 12.4.1 and 12.4.3.

12.4.1 Test Setup

- a) The unit shall be placed on a test platform.
- b) On units with adjustable features, all adjustments shall be set at the apparent least stable condition for forward stability, such as, maximum height of seat or backrest, or both, most forward seat or backrest position or both, and at the least stable condition of casters, glides and tilt mechanism.
- c) For chairs with casters, a block or obstruction 13 mm (0.5 in.) in height shall be affixed to the test platform. The device shall prevent sliding but not restrict the unit from tipping. On units that rotate, the bases and casters, if any, shall be positioned to offer the least resistance to forward tipping of the unit.
- d) For chairs without casters, a block or obstruction 13 mm (0.5 in.) in height shall be affixed to the test platform. On units that rotate, the base shall be positioned to offer the least resistance to forward tipping of the unit.

12.4.2 Test Procedure - Alternative A (See Figures 12c and 12d).

- a) This alternative may only be used on chairs that do not have a seat surface that will support the stability loading fixture (i.e., mesh, web or strap seat support surfaces).
- b) Apply a vertical load of 600 N (135 lbf.), through a 200 mm (7.87 in.) diameter disk, the center of which is 60 mm (2.4 in.) from the front center edge of the load-bearing surface of the seat. (See Figure 12e for details).
- c) Apply a horizontal force of 20 N (4.5 lbf.) at the same level of the plane of the top of the seat. The force shall be coincident with the side-to-side centerline of the seat.

12.4.3 Test Procedure - Alternative B (See Figures 12f and 12g)

- a) Apply a vertical load of 600 N (135 lbf.), by means of the front stability loading fixture shown in Figure 12g at a point 60 mm (2.4 in.) from the front center edge of the load-bearing surface of the chair.
- b) Apply a horizontal force of 20 N (4.5 lbf.) at the same level of the plane of the top of the seat. The force shall be coincident with the side-to-side centerline of the seat.

12.4.4 Acceptance Level

The chair shall not tip over as the result of the force application.

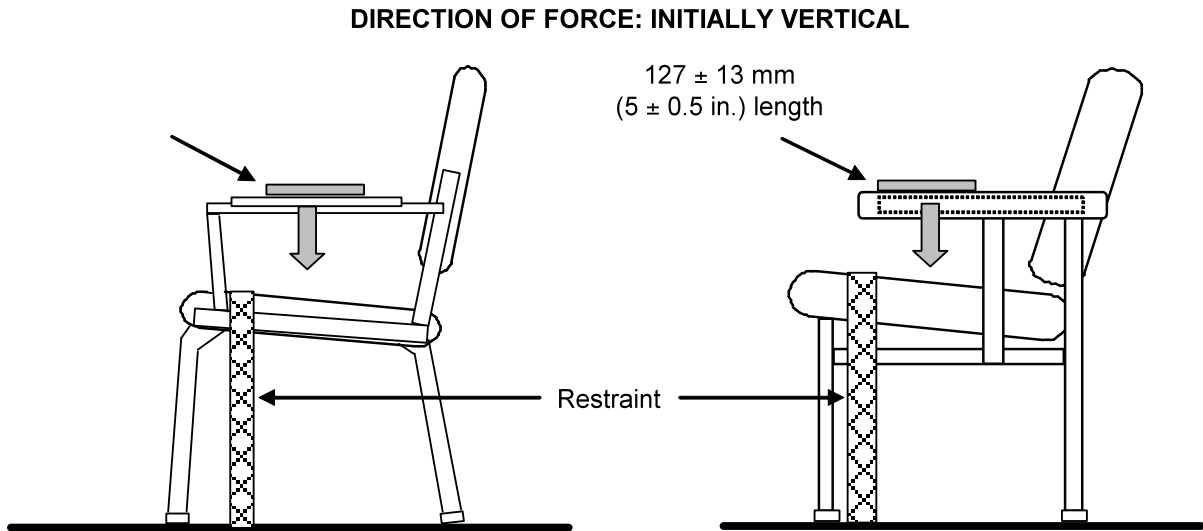

Figure 13a - Arm Strength Test - Vertical - Static

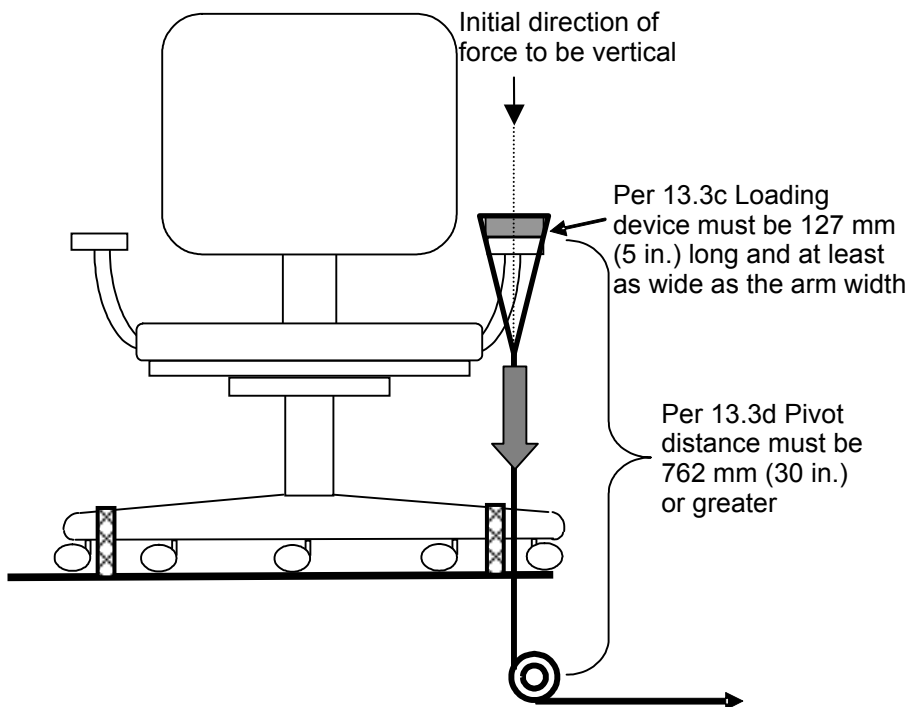

Figure 13b - Arm Strength Test - Vertical - Static

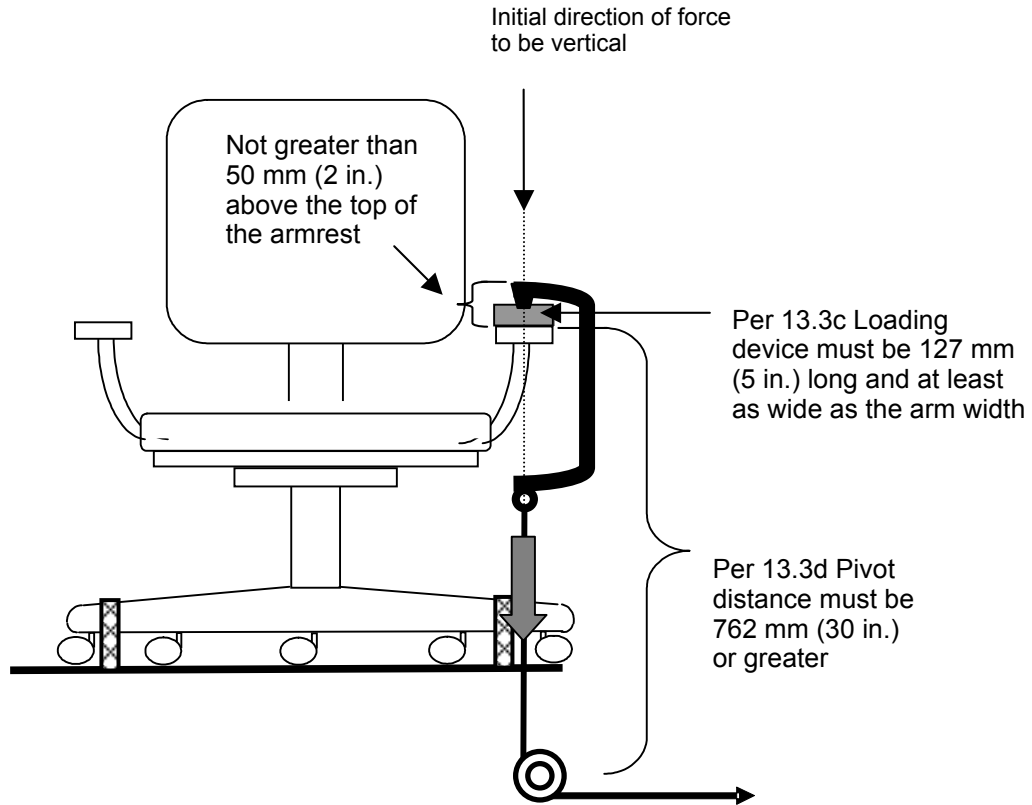

Figure 13c - Arm Strength Test - Vertical – Static (“C” Fixture Method)

13 Arm Strength Test - Vertical - Static (See Figures 13a, 13b, and 13c)

13.1 Applicability

This test applies to all chairs with arms.

13.2 Purpose of Test

The purpose of the test is to evaluate the ability of a chair and arm to withstand stresses caused by applying vertical forces on the arm(s).

13.3 Test Setup

- a) The chair shall be placed on a test platform and restrained from movement, including rotational movement of the seat. Blocking movement of the chair shall not provide a counterbalancing force that aids the support structure of the armrest under load and/or chair control/tilt mechanism. Type 3 chairs may be restrained using the seating surface (see Figure 13a)
- b) If adjustable features are available, all adjustments shall be set at normal use conditions.

- c) A loading adapter that is 127 mm (5 in.) long and at least as wide as the width of the arm shall be attached to the top of the arm rest structure such that the load will be applied at the apparent weakest point that is forward of the chair backrest.
- d) Apply an initially vertical pull force to the load adapter using a mechanism, such as a cable and pulley, having a pivot point 762 mm (30 in.) or greater below the arm. The attachment to the load adapter shall not be greater than 50 mm (2 in.) above the top of the armrest (See Figure 13b). The mechanism must allow the arm to deflect or pivot as a result of the load application. If the chair design does not allow pull force application, other methods of applying the load are acceptable as long as they allow the arm to deflect or pivot as a result of the load application.

13.4 Test Procedures

13.4.1 Functional Load

- a) A force of 750 N (169 lbf.) shall be applied for one (1) minute.
- b) Remove the force.

13.4.2 Proof Load

- a) A force of 1125 N (253 lbf.) shall be applied for one (1) minute.
- b) Remove the force.

13.5 Acceptance Level

13.5.1 Functional Load

There shall be no loss of serviceability. For a height adjustable arm, failure to hold its height adjustment position to within 6 mm (0.25 in.) from its original set position as the result of the loading is considered a loss of serviceability.

13.5.2 Proof Load

There shall be no sudden and major change in the structural integrity of the chair. For a height adjustable arm, a sudden drop in height of greater than 25 mm (1 in.) does not meet this requirement. Loss of serviceability is acceptable.

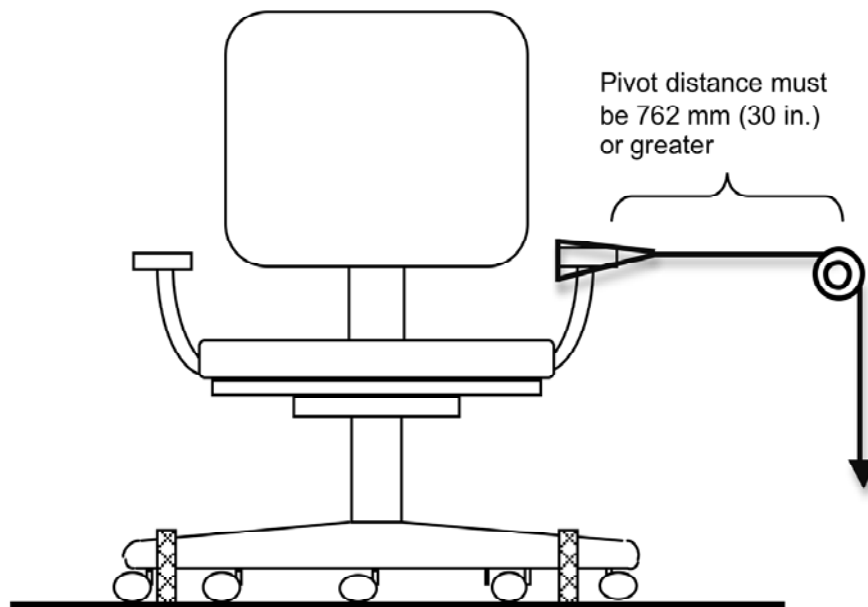

Figure 14 - Arm Strength Test - Horizontal - Static

14 Arm Strength Test - Horizontal - Static (See Figure 14)

14.1 Applicability

This test applies to all chairs with arms.

14.2 Purpose of Test

The purpose of this test is to evaluate the ability of the chair to withstand stresses caused by applying outward forces to the arm(s).

14.3 Test Setup

- a) The chair shall be placed on a test platform. Restrain the chair from horizontal movement and tipping including rotational movement of the seat. Blocking movement of the chair shall not provide a counterbalancing force that aids the support structure of the armrest under load and/or chair control/tilt mechanism. The restraints shall not restrict the chair arm movement. Figure 14 shows one acceptable method of restraining the chair.
- b) If adjustable features are available, all adjustments shall be set at normal use conditions.
- c) A loading device or strap, not greater than 25 mm (1 in.) in horizontal width, shall be attached to the arm so that the load is initially applied horizontally to the armrest structure at the apparent weakest point. For armrests that pivot in the horizontal plane, apply the load at the pivot point.
- d) Apply an initially horizontal pull force to the load adapter using a mechanism such as a cable and pulley or other mechanism having a pivot point 762 mm (30 in.) or greater from the arm. The mechanism must allow the arm to deflect as a result of the load application.

14.4 Test Procedures

14.4.1 Functional Load

- a) A force of 445 N (100 lbf.) shall be applied for one (1) minute in the outward direction.
- b) Remove the force.

14.4.2 Proof Load

- a) A force of 667 N (150 lbf.) shall be applied for one (1) minute in the outward direction.
- b) Remove the force.

14.5 Acceptance Level

14.5.1 Functional Load

A functional load applied once shall cause no loss of serviceability.

14.5.2 Proof Load

A proof load applied once shall cause no sudden and major change in the structural integrity of the unit. Loss of serviceability is acceptable.

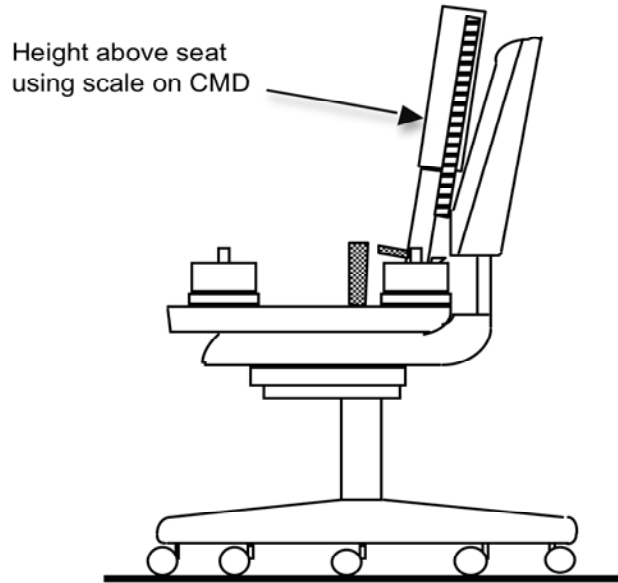

**Figure 15a - Test Height Determination
Backrest Durability Test Cyclic - Type I**

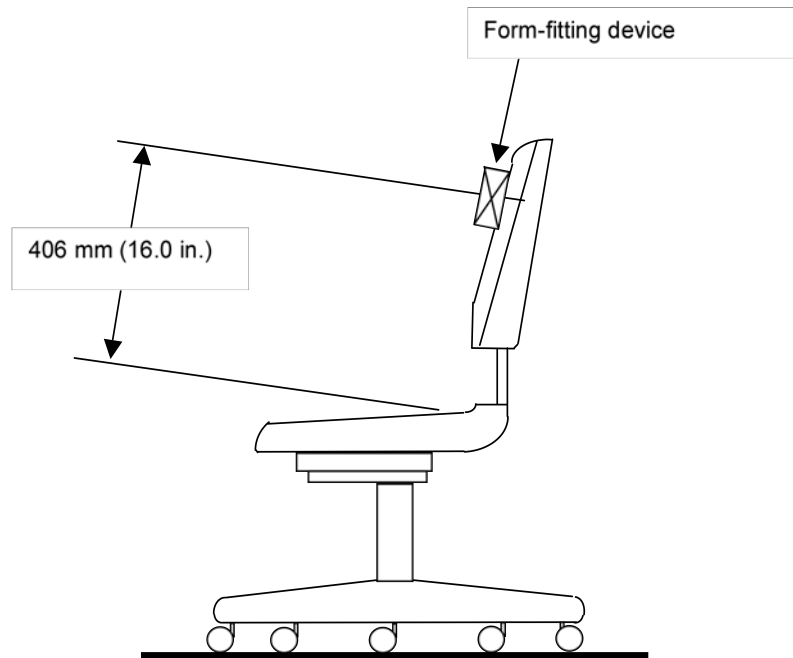

**Figure 15b - Positioning of Form-Fitting Device for Backrests Higher than 452 mm (17.8 in.)
Backrest Durability Test Cyclic - Type I**

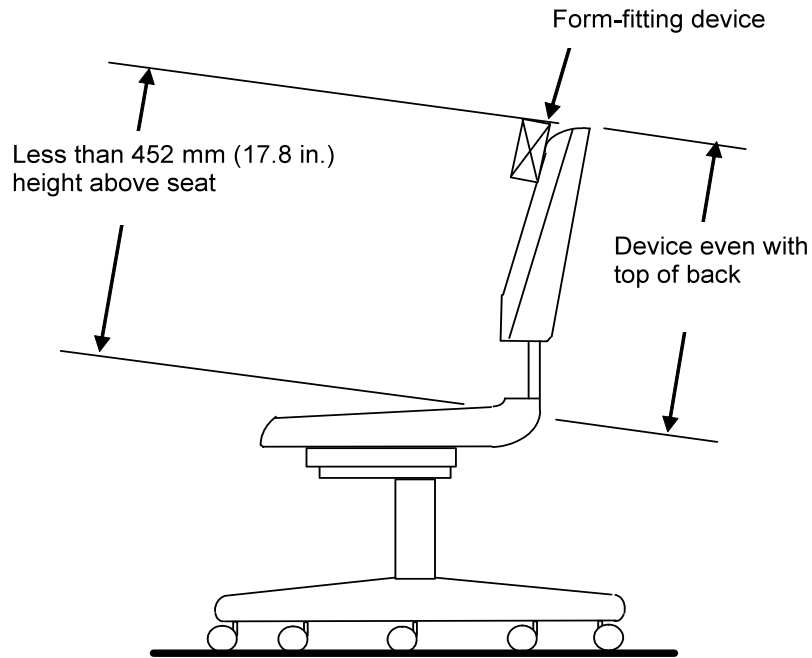

Figure 15c - Positioning of Form-Fitting Device for Backrests Lower than 452 mm (17.8 in.) Backrest Durability Test Cyclic - Type I

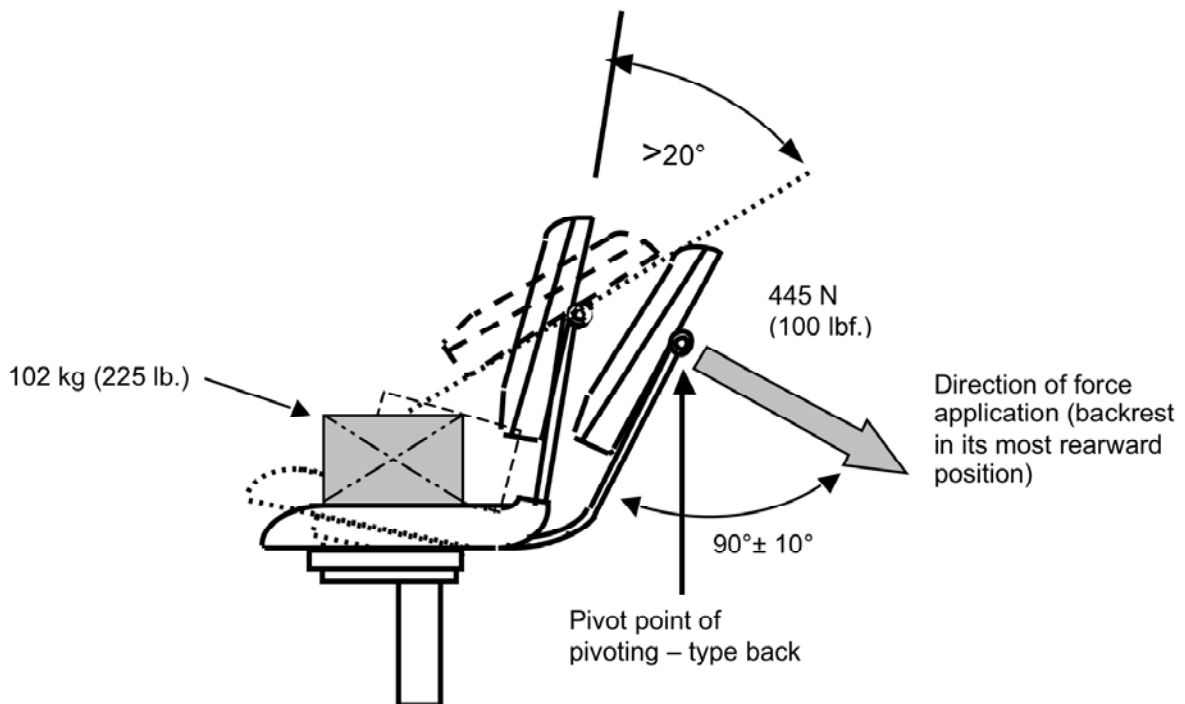
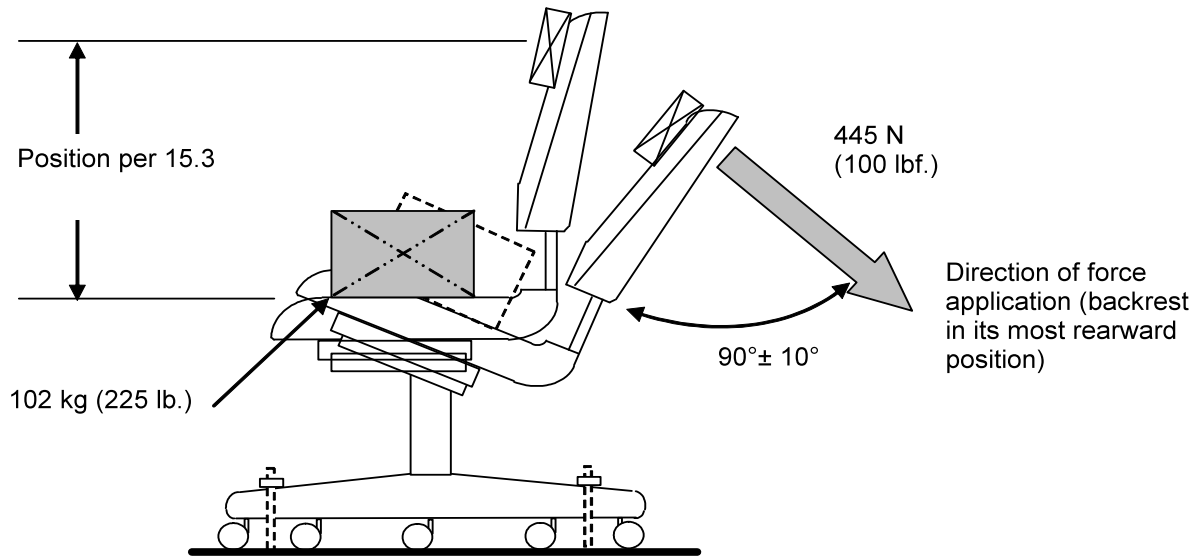

Figure 15d - Force Application for Backrests that Pivot Greater than 20° Backrest Durability Test - Cyclic - Type I



**Figure 15e - Force Application for All Other Backrests
Backrest Durability Test – Cyclic – Type I**

15 Backrest Durability Test - Cyclic - Type I (See Figures 15a through 15e)

15.1 Applicability

This test shall be performed on Type I Tilting chairs.

Note: This test does not apply to chairs with backrest height less than 200 mm (7.9 in.).

15.2 Purpose of Test

The purpose of this test is to evaluate the ability of the chairs to withstand fatigue stresses and wear caused by rearward force on the backrest of the chair.

15.3 Test Setup

15.3.1 The chair shall be placed on a test platform in an upright position with the base/legs restrained from movement. If pushing on the backrest with the test device, the chair must be restricted from rotating. Clamping shall be done so as not to restrict the movement of the backrest(s) or arm(s) of the chair.

15.3.2 If adjustable features are available, all adjustments shall be set at normal use conditions.
Note: For chairs with tilt mechanisms that lock, locking the mechanism changes the classification of the chair. (See Section 4). Chairs with tilt mechanisms in an unlocked position shall be tested according to this section and an additional chair shall also be tested according to Section 16. When testing in accordance with Section 16, the chair shall be tested in the upright locked position.

15.3.3 Determine points 406 mm (16 in.) and 452 mm (17.8 in.) above the seat (See Section 3.5). Mark these points on the vertical centerline of the backrest.

- a) If the top of the load-bearing structure/surface of the backrest is greater than or equal to 452 mm (17.8 in.) above the seat, position the center of the form-fitting device (See Definition 2.10) 406 mm (16 in.) above the seat. (See Figure 15b).
- b) If the top of the load-bearing structure/surface of the backrest is less than 452 mm (17.8 in.) above the seat, position the top of the form-fitting device even with the top of the load-bearing structure/surface. (See Figure 15c), or
- c) If the unit has a pivoting backrest that stops at a position less than or equal to 20 degrees rearward (See Figure 15d), position the form-fitting device as directed in a) or b). If the unit has a pivoting backrest that stops at a position greater than 20 degrees rearward of the backrest, position the center of the form-fitting device at the height of the pivoting point. (See Figure 15d).

15.3.4 Attach a loading device (front push or back pull) to the horizontal center of the backrest as determined above. With the backrest at its back stop position, apply a force that is initially 90 degrees \pm 10 degrees to the plane of the backrest. The force is not intended to be maintained at 90 degrees \pm 10 degrees throughout the loading of the backrest. If applying the load with a cable and pulley system, the cable must initially be a minimum of 762 mm (30 in.) in length from the attachment point to the pulley.

Note: Where the design of the chair does not allow the transfer of force(s) from the form-fitting device to the load-bearing structure/surface, then a bridging device 38 mm to 102 mm (1.5 in. to 4 in.) in height may be used to span the width of the load-bearing structure/surface. The plane of the backrest may be defined by the front of the CMD upright. (See Figure 15a).

15.3.5 A weight of 102 kg (225 lb.) shall be secured in the center of the seat.
(See Figure 15d and 15e)

15.3.6 The loading device shall be adjusted to apply a 445 N (100 lbf.) total force to the backrest. (See Figure 15e).

15.3.7 The loading device shall be set at a rate between 10 and 30 cycles per minute.

Top View: Seat Back

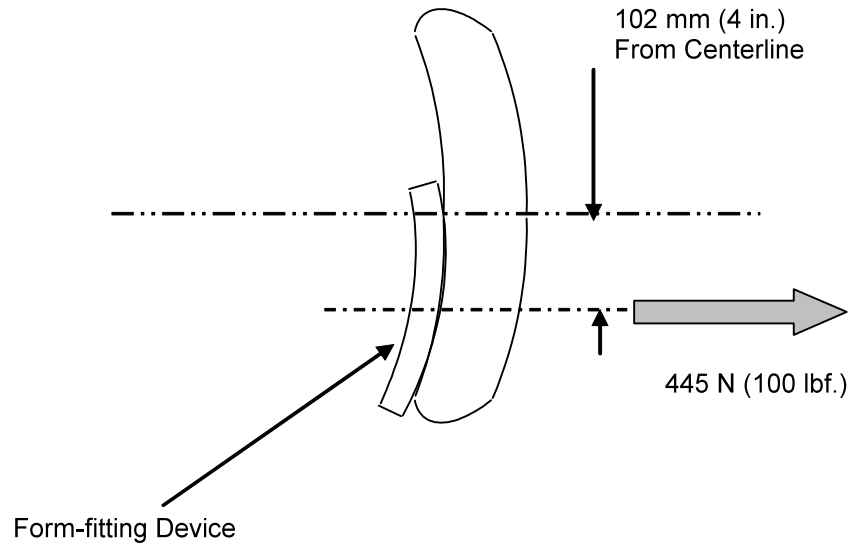

Figure 15f - Off-center Backrest Durability Loading - Left

Top View: Seat Back

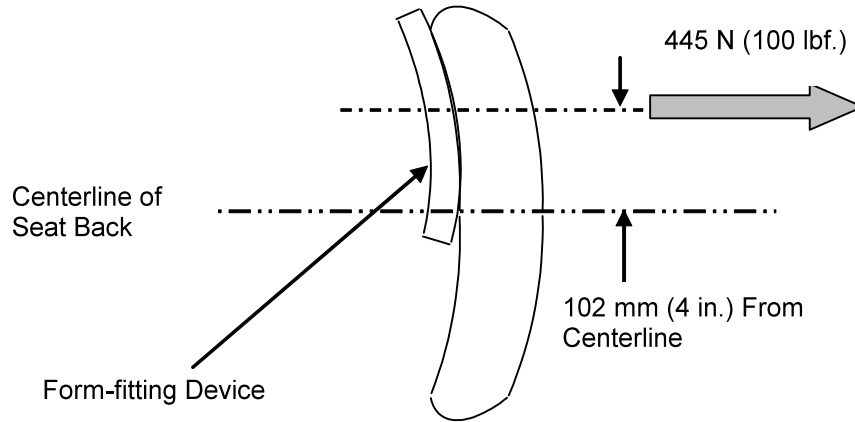

Figure 15g - Off-center Backrest Durability Loading - Right

15.4 Test Procedures

15.4.1 For chairs with backrest widths less than or equal to 406 mm (16 in.) at the height of the loading point, apply the load to the backrest for 120,000 cycles.

15.4.2 For chairs with backrest widths greater than 406 mm (16 in.) at the height of the loading point, apply the load to the backrest for 80,000 cycles.

- a) Keeping the load at the height determined above, reposition the load 102 mm (4 in.) to the right of the vertical centerline. The load may be applied through a form-fitting device if necessary. (See Figure 15f and 15g). With the backrest at its back stop position, apply a force that is initially 90 degrees \pm 10 degrees to the plane of the backrest. The force is not intended to be maintained at 90 degrees \pm 10 degrees throughout the loading of the backrest. If applying the load with a cable and pulley system, the cable must initially be a minimum of 762 mm (30 in.) in length from the attachment point to the pulley. Apply this load for 20,000 cycles.
- b) Keeping the load at the height determined above, reposition the load 102 mm (4 in.) to the left of the vertical centerline. The load may be applied through a form-fitting device if necessary. (See Figure 15f and 15g). With the backrest at its back stop position, apply a force that is initially 90 degrees \pm 10 degrees to the plane of the backrest. The force is not intended to be maintained at 90 degrees \pm 10 degrees throughout the loading of the backrest. If applying the load with a cable and pulley system, the cable must initially be a minimum of 762 mm (30 in.) in length from the attachment point to the pulley. Apply this load for 20,000 cycles.

15.5 Acceptance Level

There shall be no loss of serviceability.

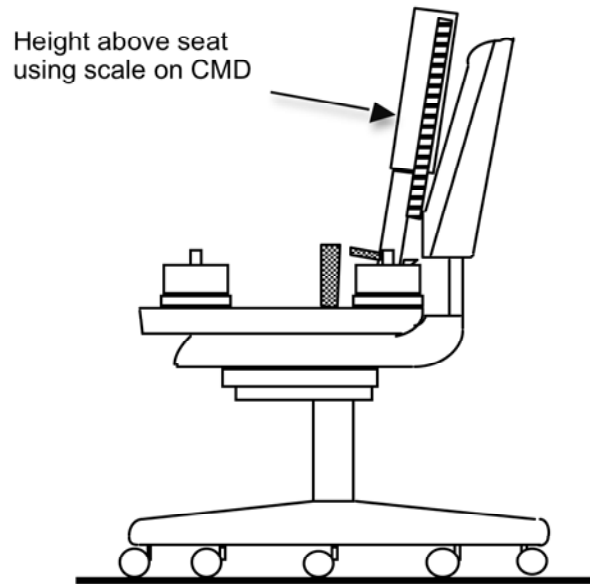

**Figure 16a - Test Height Determination
Backrest Durability Test - Cyclic - Type II and III**

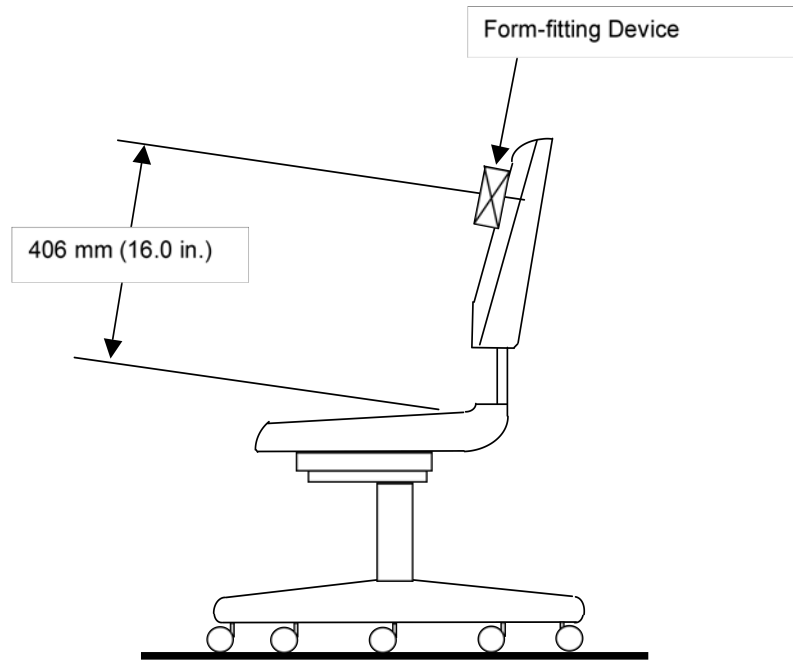

Figure 16b - Positioning of Form-Fitting Device for Backrests Higher than 452 mm (17.8 in.) Backrest Durability Test – Cyclic - Type II and III

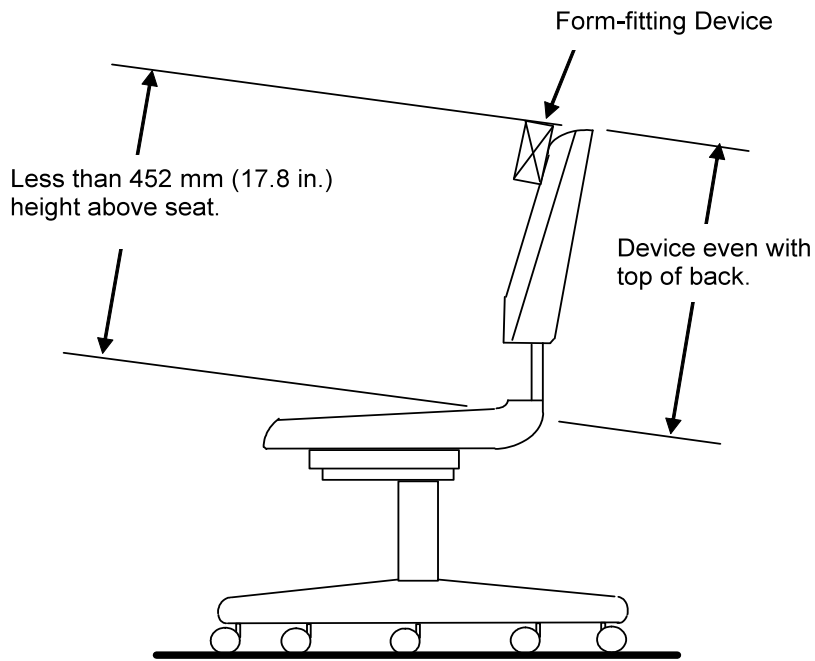
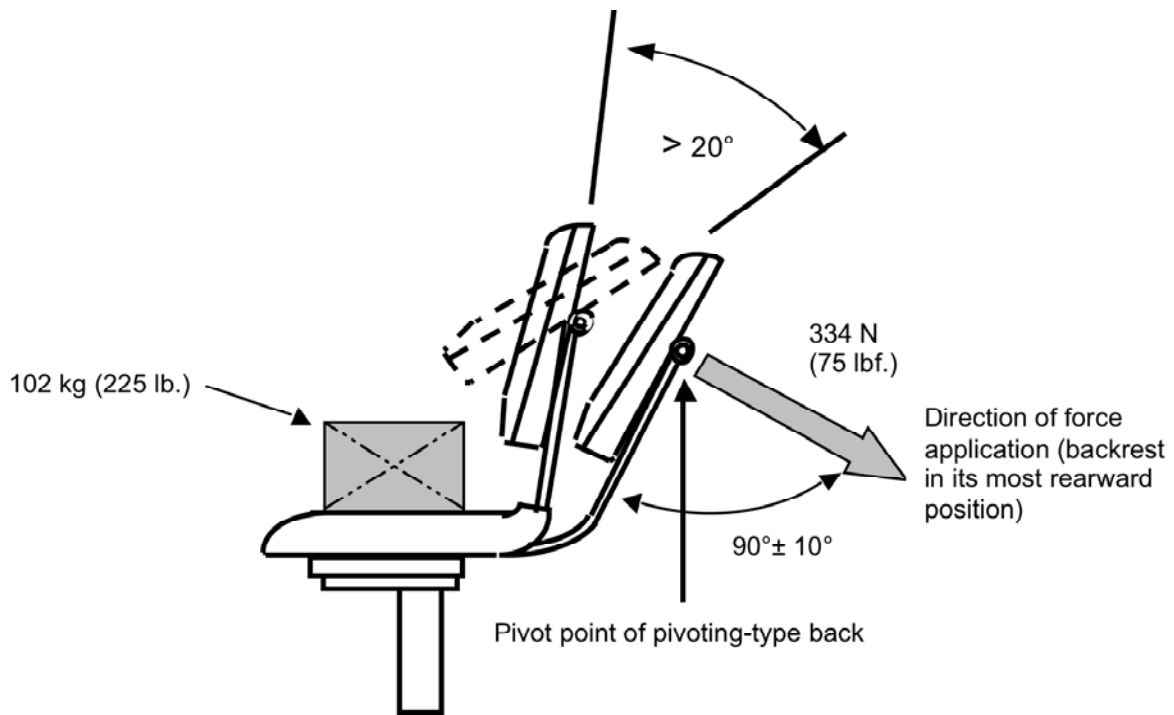
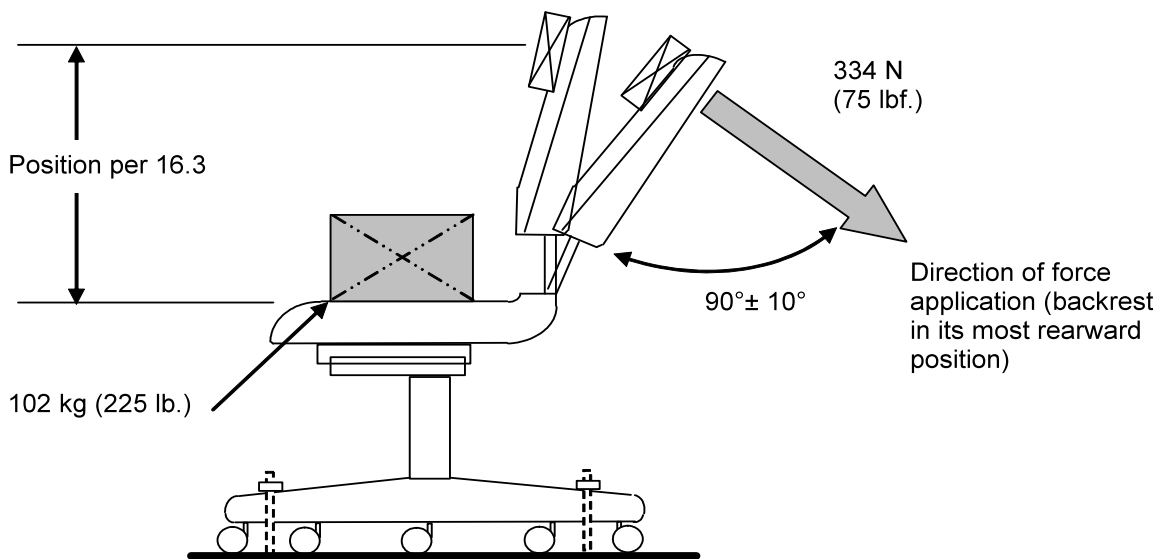

Figure 16c - Positioning of Form-Fitting Device for Backrests Lower than 452 mm (17.8 in.) Backrest Durability Test – Cyclic - Type II and III



**Figure 16d - Force Application for Backrests that Pivot Greater than 20 Degrees
Backrest Durability Test - Cyclic - Type II and III**



**Figure 16e - Force Application for All Other Backrests
Backrest Durability Test - Cyclic - Type II and III**

16 Backrest Durability Test - Cyclic - Type II and III (See Figures 16a through 16g)**16.1 Applicability**

This test shall be performed on Type II and III chairs.

Note: This test does not apply to chairs with backrest height less than 200 mm (7.9 in.).

16.2 Purpose of Test

The purpose of this test is to evaluate the ability of the chairs to withstand fatigue stresses and wear caused by rearward force on the backrest of the chair.

16.3 Test Setup

16.3.1 The chair shall be placed on a test platform in an upright position with the base/legs restrained from movement. If pushing on the backrest with the test device, the chair must be restricted from rotating. Clamping shall be done so as not to restrict the movement of the backrest(s) or arm(s) of the chair.

16.3.2 If adjustable features are available, all adjustments shall be set at normal use conditions.

16.3.3 Determine points 406 mm (16 in.) and 452 mm (17.8 in.) above the seat (See Section 3.5). Mark these points on the vertical centerline of the backrest.

- a) If the top of the load-bearing structure/surface of the backrest is greater than or equal to 452 mm (17.8 in.) above the seat, position the center of the form-fitting device (See Definition 2.9) 406 mm (16 in.) above the seat. (See Figure 16b).
- b) If the top of the load-bearing structure/surface of the backrest is less than 452 mm (17.8 in.) above the seat, position the top of the form-fitting device even with the top of the load-bearing structure/surface. (See Figure 16c).
- c) If the unit has a pivoting backrest that stops at a position less than or equal to 20 degrees rearward (See Figure 16d), position the form-fitting device as directed in a) or b). If the unit has a pivoting backrest that stops at a position greater than 20 degrees rearward of the backrest, position the center of the form-fitting device at the height of the pivoting point. (See Figure 16d).

16.3.4 Attach a loading device (front push or back pull) to the horizontal center of the backrest as determined above. With the backrest at its back stop position, apply a force that is initially 90 degrees \pm 10 degrees to the plane of the backrest. The force is not intended to be maintained at 90 \pm 10 degrees throughout the loading of the backrest. If applying the load with a cable and pulley system, the cable must initially be a minimum of 762 mm (30 in.) in length from the attachment point to the pulley.

Note: Where the design of the chair does not allow the transfer of force(s) from the form-fitting device to the load-bearing structure/surface, then a bridging device 38 mm to 102 mm (1.5 in. to 4 in.) in height may be used to span the width of the load-bearing structure/surface. The plane of the backrest may be defined by the front of the CMD upright. (See Figure 16a).

16.3.5 A weight of 102 kg (225 lb.) shall be secured in the center of the seat. (See Figure 16d and 16e).

16.3.6 The loading device shall be adjusted to apply a 334 N (75 lbf.) total force to the backrest. If the backrest/tilt lock mechanism will not accept the load due to gradual slipping of the adjustment mechanism during the load application, set the backrest to its most rearward (stopped) position, then apply the specified load(s).

16.3.7 The loading device shall be set at a rate between 10 and 30 cycles per minute.

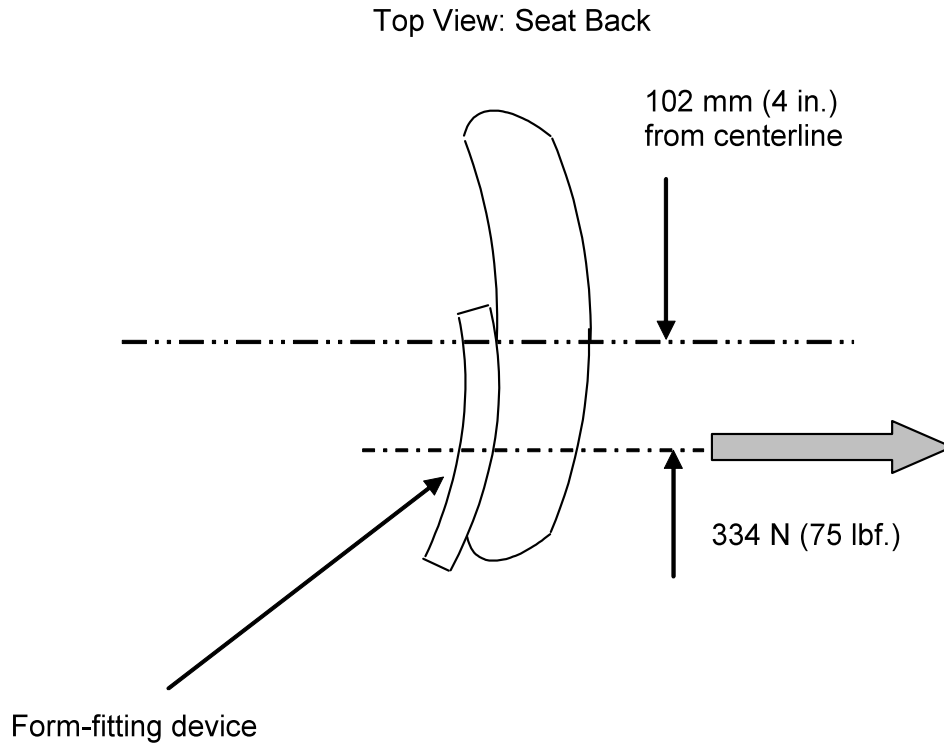

Figure 16f - Off-center Backrest Durability Loading – Cyclic – Type II and III - Left

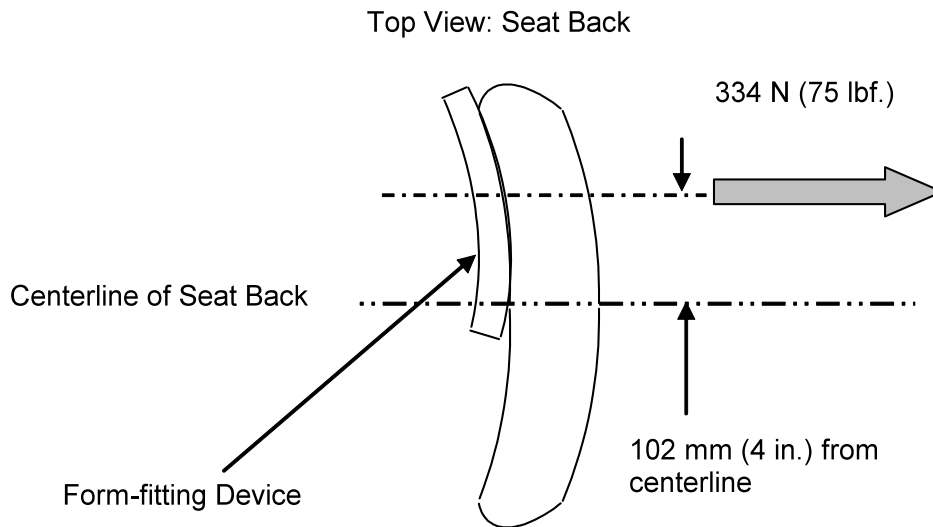

Figure 16g - Off-center Backrest Durability Loading – Cyclic – Type II and III - Right

16.4 Test Procedures

16.4.1 For chairs with backrest widths less than or equal to 406 mm (16 in.) at the height of the loading point, apply the load to the backrest for 120,000 cycles.

16.4.2 For chairs with backrest widths greater than 406 mm (16 in.) at the height of the loading point, apply the load to the backrest for 80,000 cycles.

- a) Keeping the load at the height determined above, reposition the load 102 mm (4 in.) to the right of the vertical centerline (See Figure 16f and 16g). With the backrest at its back stop position, apply a force that is initially 90 degrees \pm 10 degrees to the plane of the backrest. The force is not intended to be maintained at 90 degrees \pm 10 degrees throughout the loading of the backrest. If applying the load with a cable and pulley system, the cable must initially be a minimum of 762 mm (30 in.) in length from the attachment point to the pulley. Apply this load for 20,000 cycles.
- b) Keeping the load at the height determined above, reposition the load 102 mm (4 in.) to the left of the vertical centerline (See Figure 16f and 16g). With the backrest at its back stop position, apply a force that is initially 90 degrees \pm 10 degrees to the plane of the backrest. The force is not intended to be maintained at 90 degrees \pm 10 degrees throughout the loading of the backrest. If applying the load with a cable and pulley system, the cable must initially be a minimum of 762 mm (30 in.) in length from the attachment point to the pulley. Apply this load for 20,000 cycles.

16.5 Acceptance Level

There shall be no loss of serviceability.

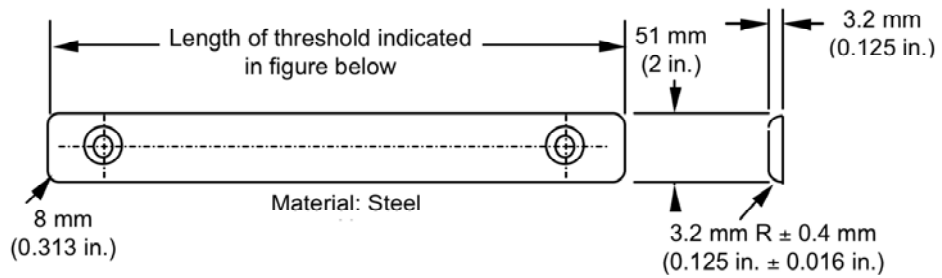

Figure 17a - Obstacle Detail

Typical All Sides

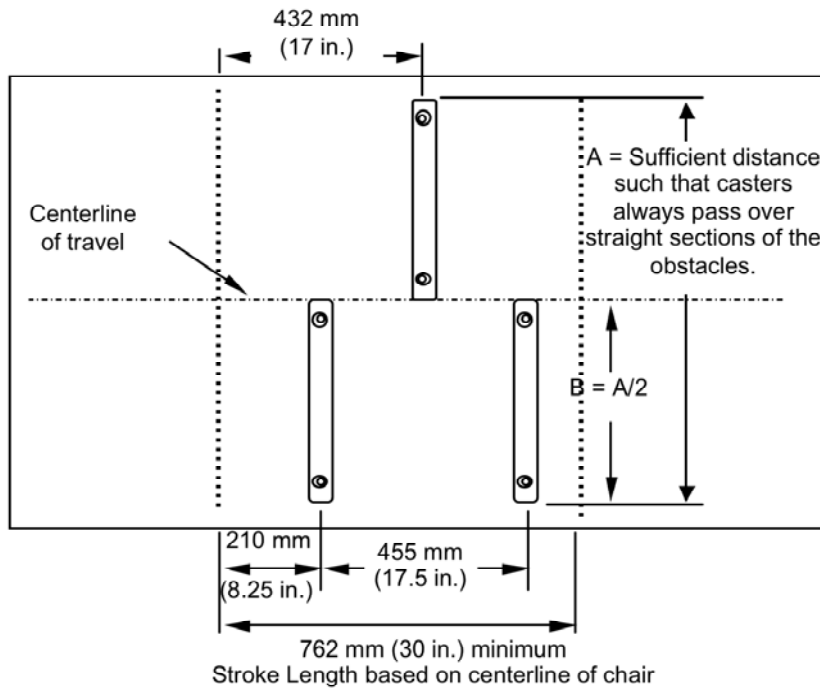

Figure 17b - Obstacle Layout for Pedestal Base Chairs

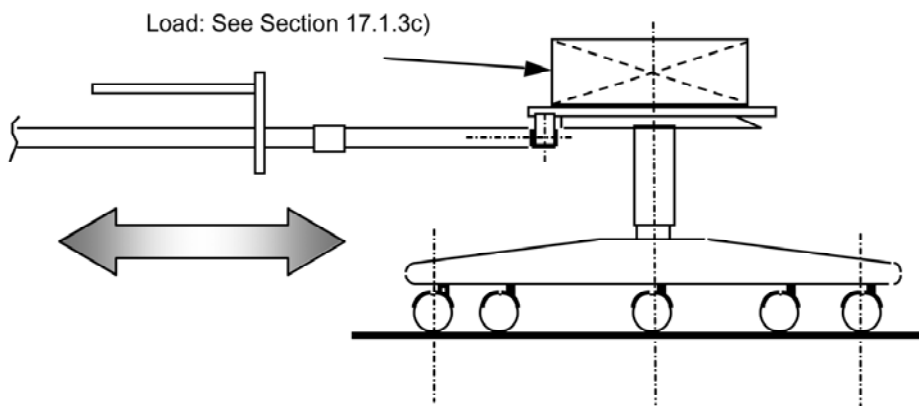

Figure 17c - Machine Schematic for Pedestal Base Chairs

Figures 17a through 17c - Caster/Chair Base Durability Test - Cyclic

17 Caster/Chair Base Durability Test - Cyclic (See Figures 17a through 17e)**17.1 Caster/Chair Base Durability Test for Pedestal Base Chairs****17.1.1 Applicability**

This test applies to pedestal base chairs with casters.

17.1.2 Purpose of Test

The purpose of this test is to evaluate the ability of the chair base and casters to withstand fatigue stresses and wear caused by moving the chair back and forth.

17.1.3 Test Setup

- a) The chair, or chair base with casters, shall be attached to a cycling device similar to Figure 17c. When testing a full chair, set all adjustments to midpoint.
- b) The chair shall be cycled on a smooth hard surface with three obstacles as shown in Figure 17a in accordance with the obstacle layout as shown in Figure 17b.
- c) If a complete chair is to be tested, place a 113 kg (250 lb.) load on the seat of the chair. If a fixture is used, the weight of the test assembly (base assembly, fixture and weights) shall be equivalent to 113 kg (250 lb.) plus the weight of the chair in its fully assembled configuration. (See Figure 17c). The base and casters shall be free to rotate and swivel.
- d) The stroke of the cycling device shall be adjusted to ensure a minimum of 762 mm (30 in.) of travel. The stroke shall be oriented so the casters roll across the test platform and obstacles as shown in Figure 17b.
- e) The cycling device shall be operated at a rate of 10 ± 2 cycles per minute. One cycle shall consist of a forward and backward stroke of the cycling device.

17.1.4 Test Procedure

- a) The chair or chair base shall be cycled 2,000 cycles over the obstacles as shown in Figure 17b and then 98,000 cycles on a smooth, hard surface without obstacles.
- b) Evaluate the product in accordance with the acceptance level in 17.1.5.1.
- c) At the conclusion of cycling, a 22 N (5 lbf.) pull force shall be applied to each caster in line with the caster stem centerline.
- d) Evaluate the product in accordance with the acceptance level in 17.1.5.2.

17.1.5 Acceptance Level**17.1.5.1 Durability cycling**

There shall be no loss of serviceability.

17.1.5.2 Caster Retention

No part of the caster shall separate from the chair as a result of the application of the 22 N (5 lbf.) force.

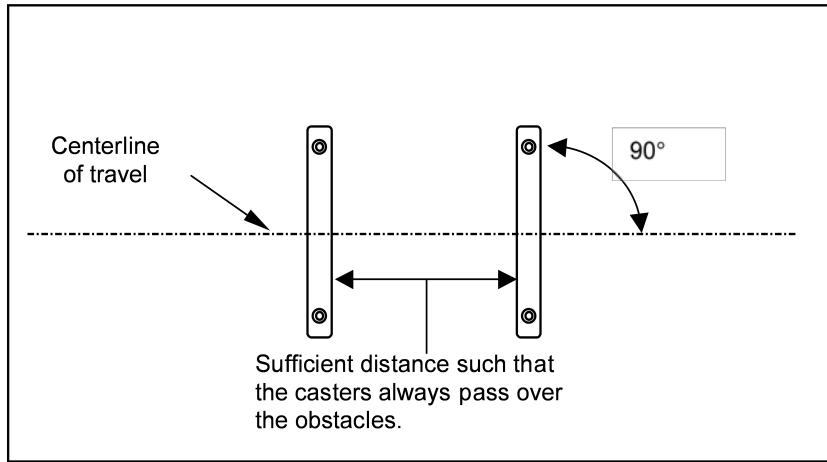

Figure 17d - Obstacle Layout for Chairs with Legs

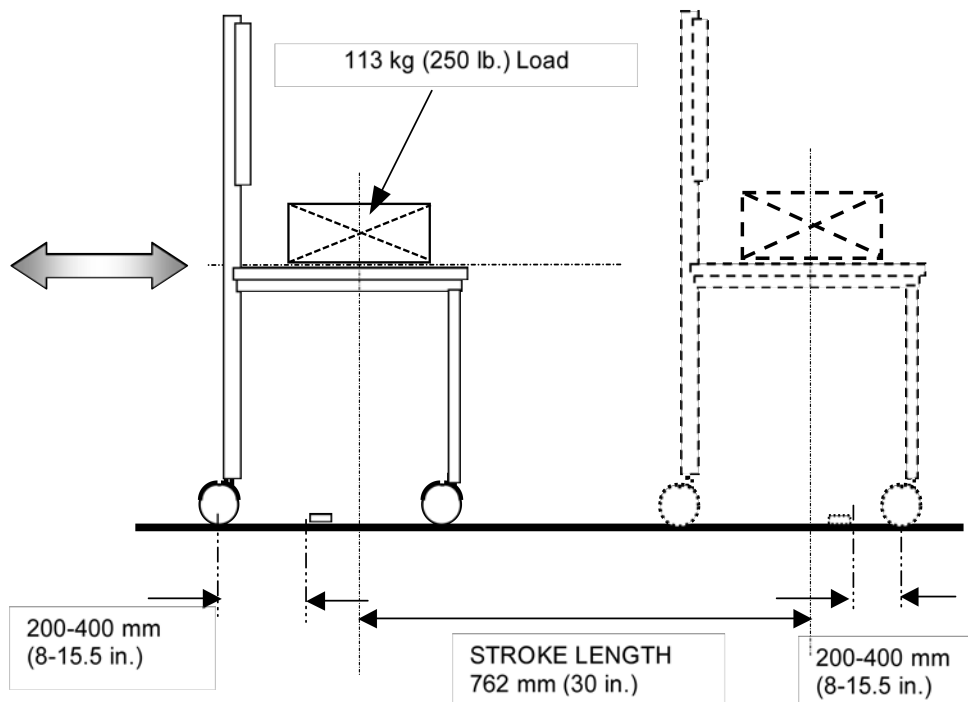

Figure 17e - Machine Schematic for Chairs with Legs

Figure 17d & 17e Caster/Chair Base Durability Test - Cyclic Obstacle Layout and Machine Stroke

17.2 Caster/Chair Frame Durability Test for Chairs with Legs

17.2.1 Applicability

This test applies to chairs with legs and casters. This test is not applicable to chairs with glide/caster combinations (i.e., those having two glides and two casters).

17.2.2 Purpose of Test

The purpose of this test is to evaluate the ability of the chair frame and casters to withstand fatigue stresses and wear caused by moving the chair back and forth.

17.2.3 Test Setup

- a) The chair, or chair frame with casters, shall be attached to a cycling device similar to Figure 17e. The cycling device shall be attached to apply the horizontal motion at the highest point that does not cause the chair to tip or lift the casters entirely off the platform during the test but not any higher than 25 mm (1 in.) above the bottom of the applied weight.
- b) The chair shall be cycled on a smooth hard surface with two obstacle layout as shown in Figure 17d and 17e in accordance with the obstacle detail as shown in Figure 17a.
- c) Place and secure a distributed 113 kg (250 lb.) on the center of seat of the chair or chair base. The casters shall be free to rotate and swivel.

Note: Some chairs of this type have fixed rear casters. If that is the case, the casters should roll freely.

- d) The stroke of the cycling device shall be adjusted to ensure a minimum of 762 mm (30 in.) of travel. The stroke shall be set and the obstacles shall be oriented such that the casters roll across the test platform and obstacles, and that each caster travels beyond the obstacle by 200 to 400 mm (8 to 15.5 in.) in each direction as shown in Figure 17e.
- e) The cycling device shall be operated at a rate of 10 ± 2 cycles per minute. One cycle shall consist of a forward and backward stroke of the cycling device.

17.2.4 Test Procedure

- a) The chair or chair base shall be cycled for 2,000 cycles over the obstacles as shown in Figures 17d and 17e and then 98,000 cycles on a smooth hard surface without obstacles.
- b) Evaluate the product in accordance with the acceptance level in 17.2.5.1.
- c) At the conclusion of cycling, a 22 N (5 lbf.) pull force shall be applied to each caster in line with the caster stem centerline.

17.2.5 Acceptance Level

17.2.5.1 Durability Cycling

There shall be no loss of serviceability.

17.2.5.2 Caster Retention

No part of the caster shall separate from the chair as a result of the application of the 22 N (5 lbf.) force.

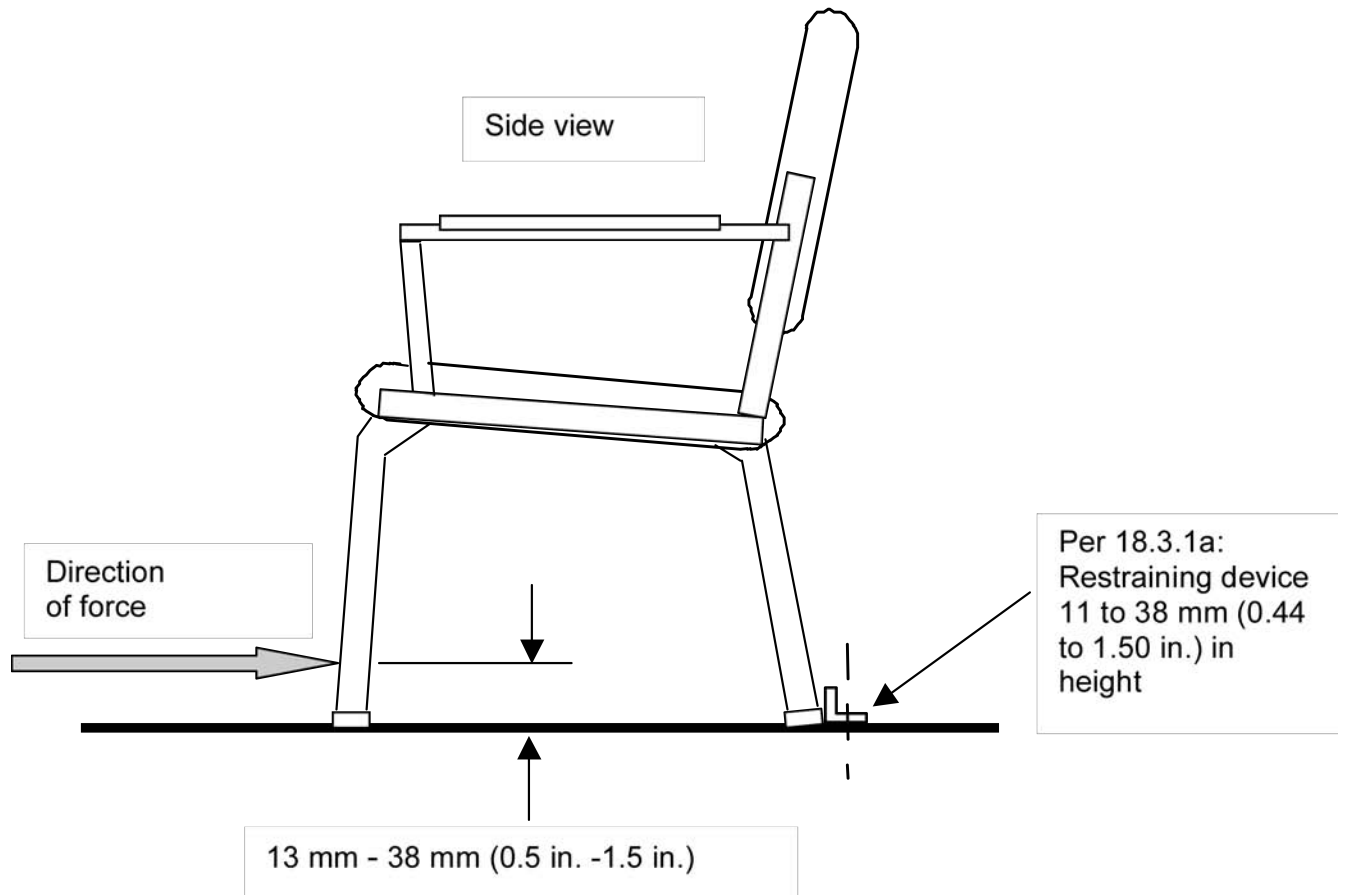

Figure 18a - Leg Strength Test - Front Application

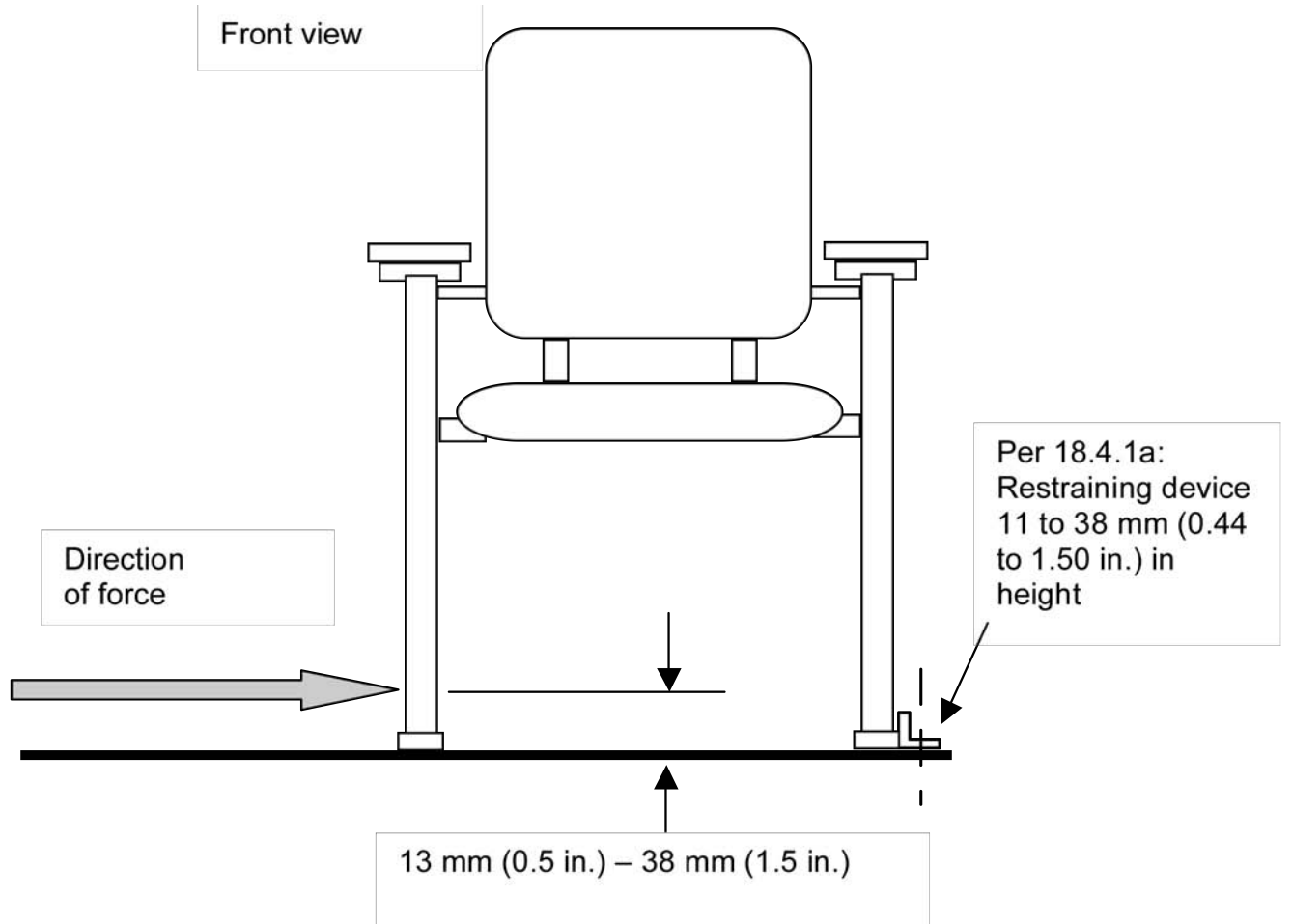

Figure 18b - Leg Strength Test - Side Application

18 Leg Strength Test - Front and Side Application (See Figure 18a & 18b)

18.1 Applicability

This test applies to all chairs without pedestal bases.

18.2 Purpose of Test

The purpose of this test is to evaluate the ability of legs to withstand horizontal side and frontal forces.

18.3 Front Load Test

18.3.1 Test Setup

- a) The chair shall be placed on a test platform, with the back legs restrained by a block 11 to 38 mm (.44 to 1.50 in.) high. Figure 18a shows one acceptable method of restraining the chair.
- b) If adjustable features are available, all adjustments shall be set at normal use conditions.
- c) The loading device shall be attached to the chair so that an initially horizontal force is applied inward and parallel to the front-to-rear axis of the chair, between 13 mm (0.5 in.) and 38 mm (1.5 in.) from the bottom of a leg as shown in Figure 18a. For chairs with casters, apply the load to the chair leg, but not more than 13 mm (0.5 in.) from the point of caster attachment (bottom of the leg). The load shall be applied to the apparent weakest point of the leg. Where the apparent weakest point is the left or right edge of the leg, apply the load so that it is no greater than 25 mm (1.0 in.) from the edge.

18.3.2 Test Procedures

18.3.2.1 Functional Load Test

- a) A force of 334 N (75 lbf.) shall be applied once to each front leg individually for one (1) minute.
- b) Remove the force.

18.3.2.2 Proof Load Test

- a) A force of 503 N (113 lbf.) shall be applied once to each front leg individually for one (1) minute.
- b) Remove the force.

18.4 Side Load Test

Note: A separate chair may be used for the side load portion of the test.

18.4.1 Test Setup

- a) The chair shall be placed on a test platform with the side leg(s) restrained by a block 11 to 38 mm (.44 to 1.50 in.) high. Figure 18b shows one acceptable method of restraining the chair.
- b) If adjustable features are available, all adjustments shall be set at normal use conditions.
- c) The loading device shall be attached to the chair so that an initially horizontal force is applied inward and parallel to the side-to-side axis of the chair, between 13 mm (0.5 in.) and 38 mm (1.5 in.) from the bottom of a leg as shown in Figure 18b. For chairs with casters, apply the load to the chair leg, but not more than 13 mm (0.5 in.) from the point of caster attachment (bottom of the leg). The load shall be applied to the apparent weakest point (front-to-back) of the leg. Where the apparent weakest point is the front or rear edge of the leg, apply the load so that it is no greater than 25 mm (1.0 in.) from the edge.

18.4.2 Test Procedure

18.4.2.1 Functional Load Test

- a) A force of 334 N (75 lbf.) shall be applied once to a front and rear leg individually for one (1) minute.
- b) Remove the force.

18.4.2.2 Proof Load Test

- a) A force of 503 N (113 lbf.) shall be applied once to a front and rear leg individually for one (1) minute.
- b) Remove the force.

18.5 Acceptance Level - Front and Side Load Tests

18.5.1 Functional Load

Functional load(s) applied once in each direction shall cause no loss of serviceability.

18.5.2 Proof Load

Proof load(s) applied once each direction shall cause no sudden and major change in the structural integrity of the chair. Loss of serviceability is acceptable.

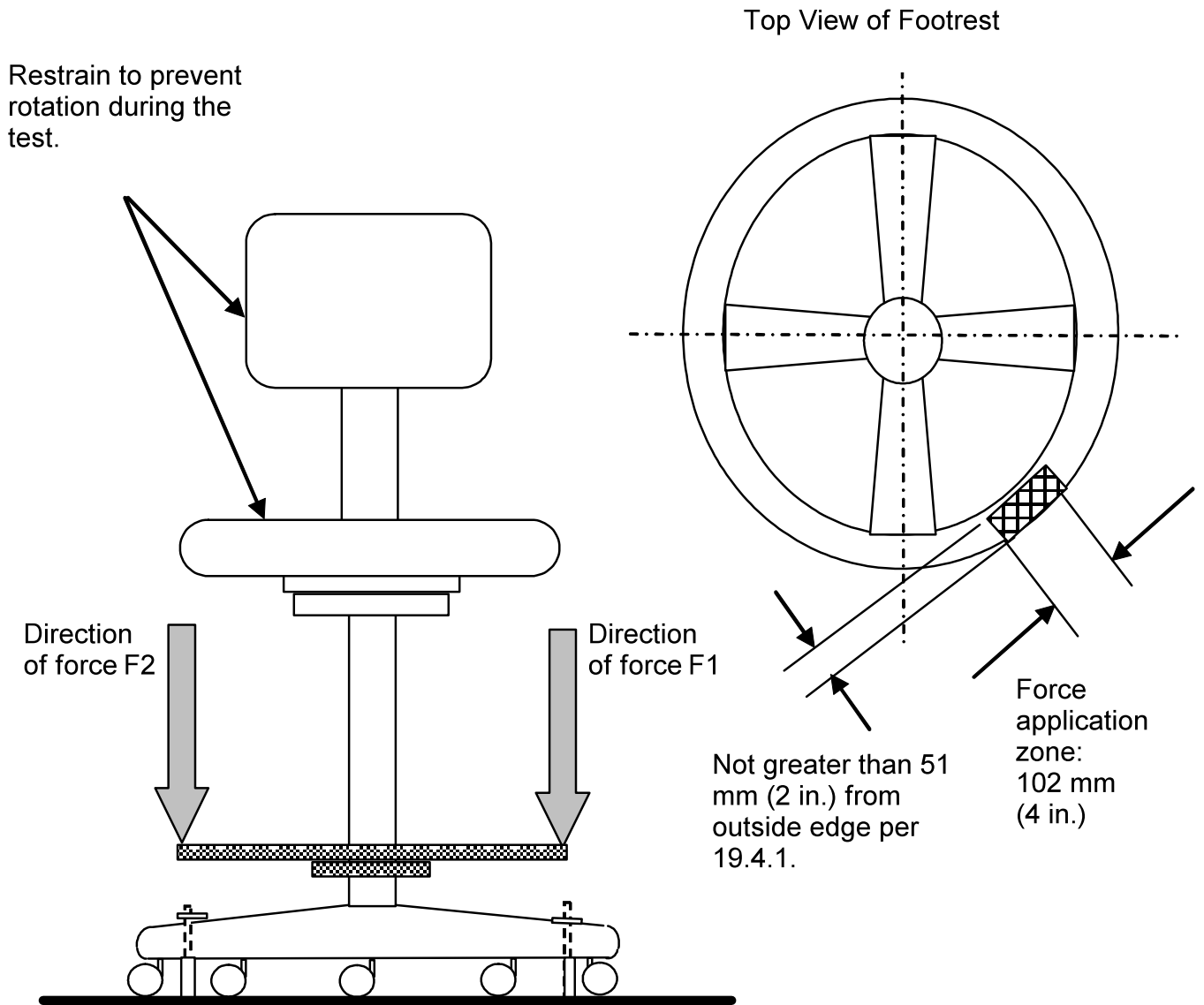

Figure 19 - Footrest Static Load Test - Vertical

19 Footrest Static Load Test - Vertical (See Figure 19)

19.1 Applicability

The footrest static load test shall be performed on all chairs with a footrest feature and a seat height equal to or greater than (or can be adjusted to) 610 mm (24 in.).

19.2 Purpose of Test

The purpose of this test is to evaluate the ability of the footrest to withstand static loading stresses.

19.3 Functional Load Test

19.3.1 Test Set Up

- a) The chair shall be placed on a test platform and restrained as shown in Figure 19.
- b) On chairs with adjustable features, all adjustments shall be set at normal use position. The seat and upper structure shall be restrained as necessary to prevent rotation during the test. Chair cushions and/or other components not related to the structure of the footrest may be removed to facilitate load application.

Note: This test is not intended to evaluate the performance of casters or glides. Casters may be removed, left in place or replaced by spacers to provide clearance if necessary.

19.4 Test Procedures

19.4.1 Static Load Test – Functional Load

- a) Apply a force F1 of 445 N (100 lbf.) uniformly along a 102 mm (4 in.) distance along the footrest but not greater than 51 mm (2 in.) from the outside edge at the apparent weakest point of the structure for one (1) minute in the vertical downward direction. (See Figure 19: Top View of Footrest). If the footrest adjusts in height relative to the seat and allows for a force application 180 degrees (on the opposite side of the chair) from the primary force application, maintain force F1 and apply an additional force F2 of 445 N (100 lbf.) to the footrest at the opposing position for an additional one (1) minute. The F2 force shall also be applied uniformly along a 102 mm (4 in.) distance along the footrest but not greater than 51 mm (2 in.) from the outside edge.
- b) If applicable, remove force F2.
- c) Increase the force F1 to 200 lbf. for one (1) minute.

19.4.2 Acceptance level

There shall be no loss of serviceability or sudden loss of footrest height.

19.4.3 Static Load Test – Proof Load

Apply a force of 1334 N (300 lbf.) uniformly along a 102 mm (4 in.) distance along the footrest but not greater than 51 mm (2 in.) from the outside edge at the apparent weakest point of the structure for one (1) minute in the vertical downward direction.

19.5 Acceptance level

The load applied once shall cause no sudden and major change in the structural integrity of the unit. Loss of serviceability is acceptable.

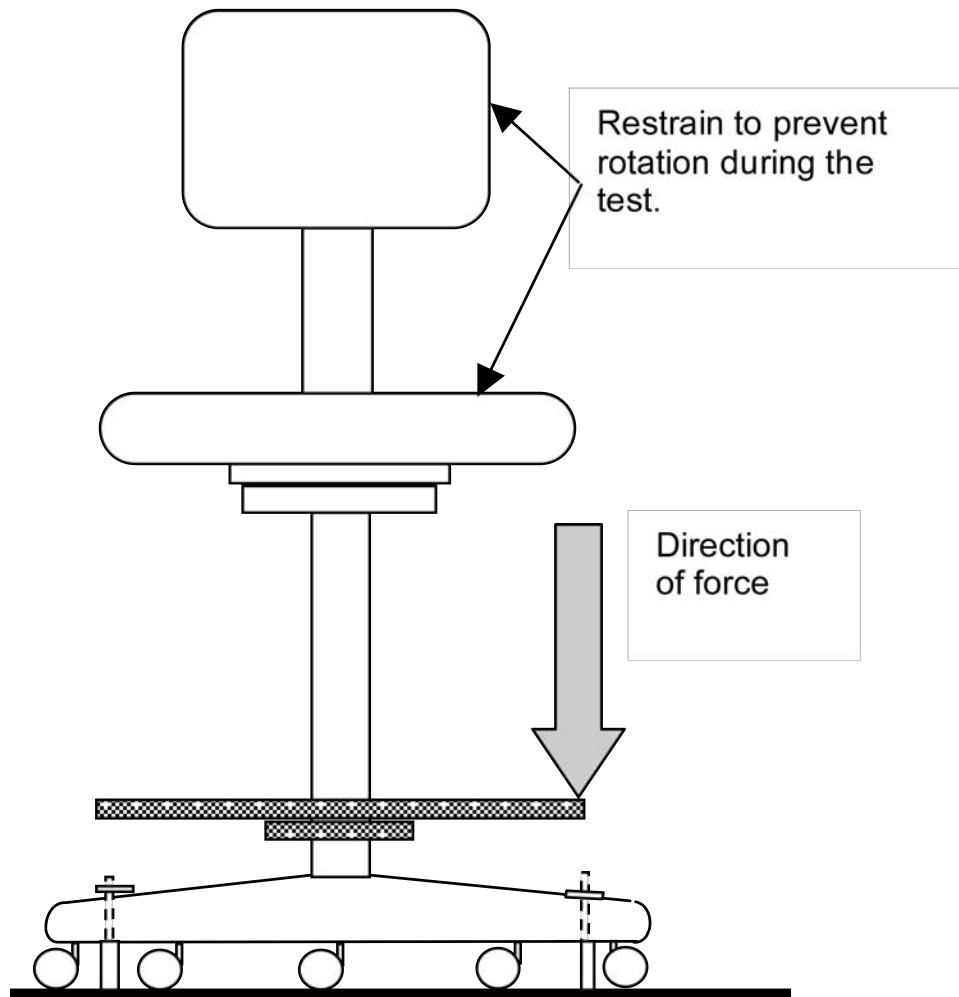

Figure 20 - Footrest Durability Test - Vertical - Cyclic

20 Footrest Durability Test - Vertical - Cyclic (See Figure 20)

20.1 Applicability

The footrest durability test shall be performed on all chairs with a footrest feature.

20.2 Purpose of Test

The purpose of this test is to evaluate the ability of the footrest to withstand stresses that occur as a result of repetitive loading.

20.3 Test Set Up

- a) The chair shall be placed on a test platform and restrained as shown in Figure 20.
- b) On chairs with adjustable features, all adjustments shall be set at normal use position. The seat and upper structure shall be restrained as necessary to prevent rotation during the test. Chair cushions and/or other components not related to the structure of the footrest may be removed to facilitate load application.

Note: This test is not intended to evaluate the performance of casters or glides. Casters may be removed, left in place or replaced by spacers to provide clearance if necessary.

20.4 Test Procedure

- a) A 890 N (200-lbf.) force shall be applied uniformly along a 102 mm (4 in.) distance along the footrest but not greater than 51 mm (2 in.) from the outside edge at the apparent weakest point of the structure. (See Figure 19: Top View of Footrest). When the weakest position is not obvious, several load application positions may be necessary to properly test the product. If the footrest moves more than 25 mm (1 in.) within the first 500 cycles, discontinue testing (See 20.5 Acceptance level). If the footrest moves throughout the remainder of the test, reset it to its original position when it is within 12 mm (0.5 in.) from its lowest position.
- b) The force shall be applied and removed 50,000 cycles at a rate between 10 and 30 cycles per minute.

20.5 Acceptance level

There shall be no loss of serviceability. Adjustable footrests that move more than 25 mm (1 in.) in the first 500 cycles shall be considered to have lost their serviceability.

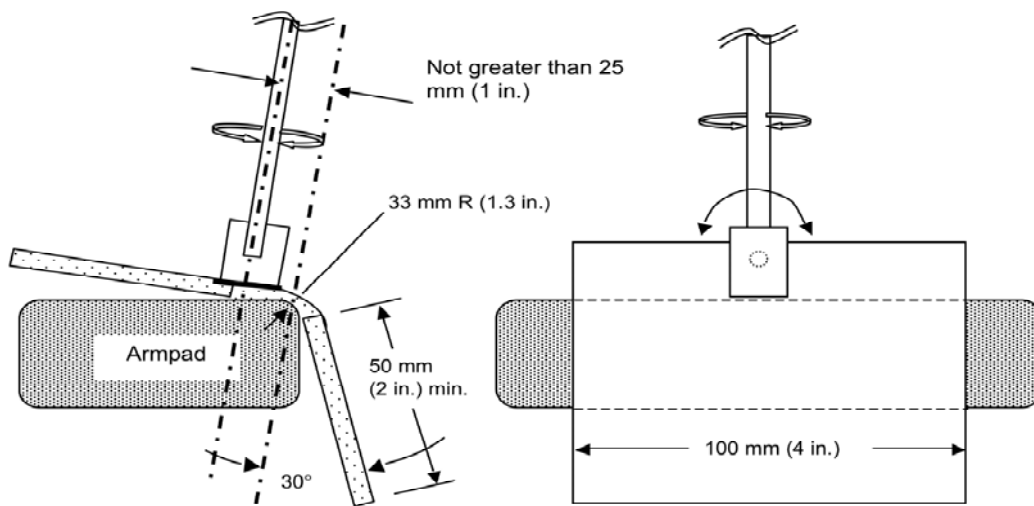

Figure 21a - Arm Loading Device

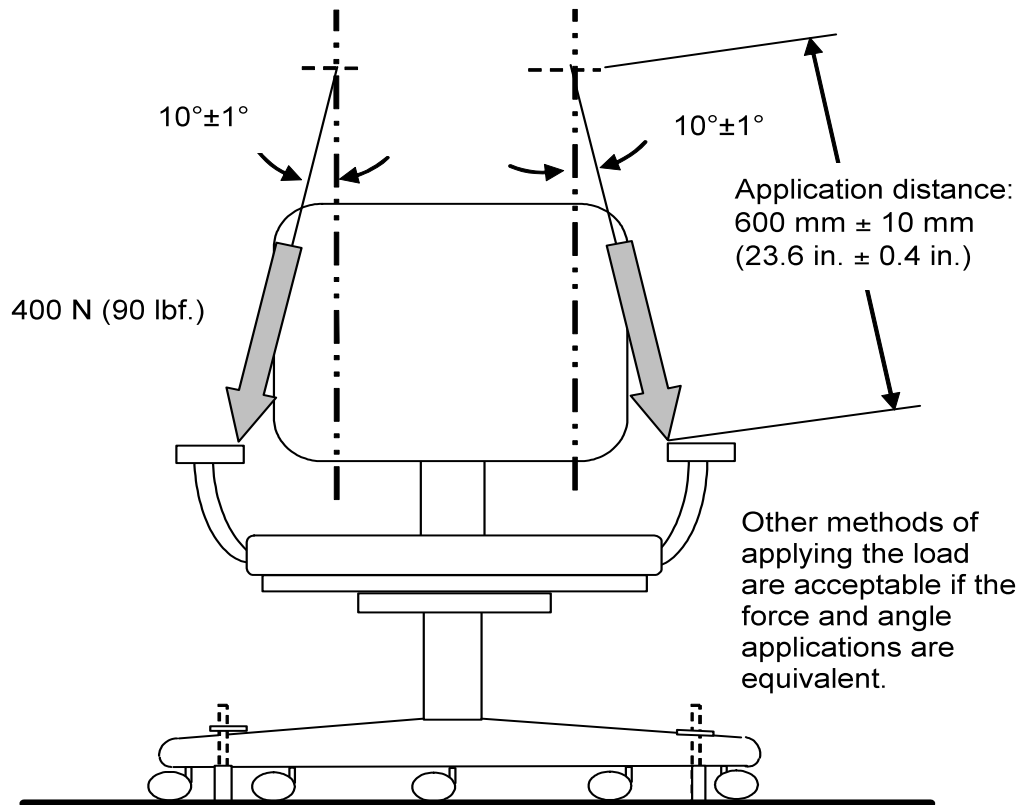

Figure 21b - Arm Durability Test - Cyclic

21 Arm Durability Test - Cyclic (Figure 21a and 21b)

21.1 Purpose of test

The purpose of this test is to evaluate the ability of the chair armrests to withstand stresses that occur as a result of repetitive loading that can be imposed on the armrest structure. Loading of this type is the result of using the armrests as a support when getting into or out of the chair.

21.2 Test setup

- a) The chair shall be placed on a test platform in an upright position as shown in Figure 21b. If necessary, the seat may be restrained from rotational movement. Clamping shall be done in such a manner as not to restrict the arms of the unit.
- b) Height-adjustable arms must be set at the apparent weakest position. When the weakest position is not obvious, several load applications positions may be necessary to properly test the product.
- c) Width-adjustable arms must be set at the apparent weakest position.
- d) Unrestrained pivoting armrests (i.e., the armrest cap pivots freely) shall be loaded in line with the pivot point.
- e) The arm loading device should distribute the load over a length of 100 mm (4 in.) on the arm pad. Center of load shall not be applied more than 25 mm (1.0 in.) in from the inside edge of the arm pad. One suggested arm loading device is shown in Figure 21a. Position the arm loading device on the armrest structure at its apparent weakest point consistent with using the armrest as a support for entering or exiting the chair.

21.3 Test procedure

Simultaneously apply a force of 400 N (90 lbf.) to each arm initially at a 10 degrees \pm 1 degree angle as shown in Figure 21b. The arm loading device must follow the arm as it deflects or pivots. The fixture linking the arm loading device to the armrest pad shall stay in contact with the arm pad throughout the loading cycle. If using a test device similar to that shown in Figure 21b, the load application distance must initially be the length specified in the figure. Other methods of applying the load are acceptable if the force and angle applications are equivalent. The force shall be applied and removed for 60,000 cycles at a rate between 10 and 30 cycles per minute.

21.4 Acceptance level

There shall be no loss of serviceability to the chair.

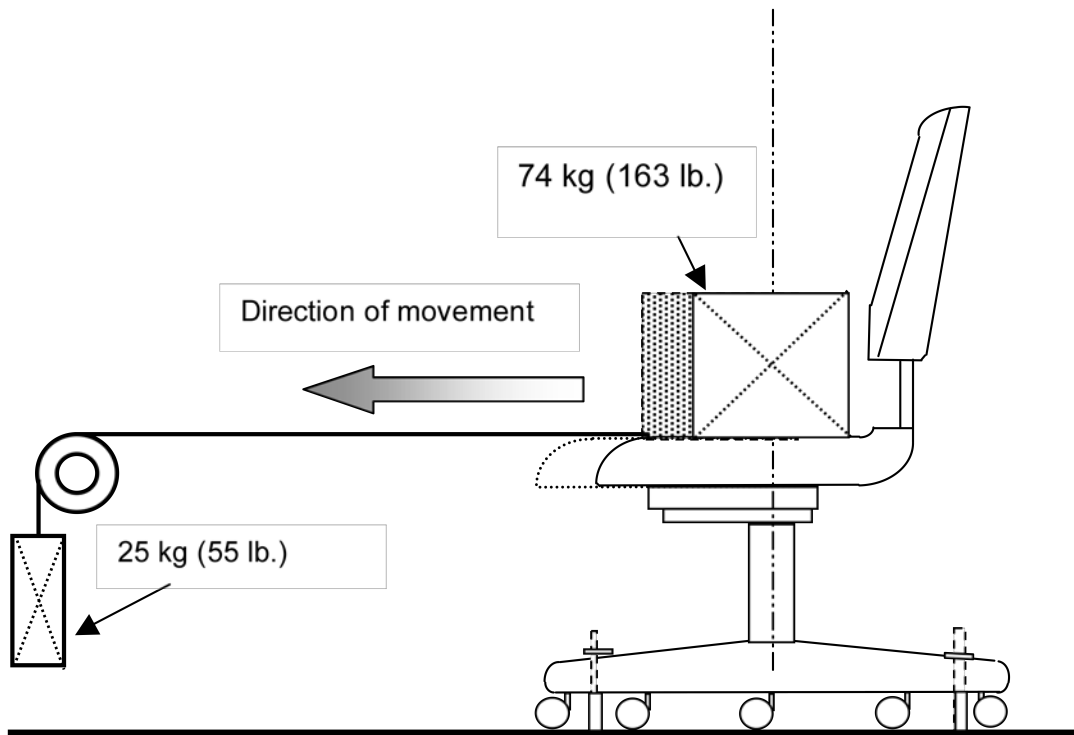

Figure 22 - Out Stop Test for Chairs with Manually Adjustable Seat Depth

22 Out Stop Tests for Chairs with Manually Adjustable Seat Depth (See Figure 22)

22.1 Purpose of Test

The purpose of this test is to evaluate the ability of the seat slide out stops to withstand excessive impact forces that may result from user adjustment of the seat depth.

Note: This test does not apply to chairs where seat depth adjustments must occur with the user out of the chair.

22.2 Test Setup

- a) The chair shall be placed on a test platform and restrained to prevent it from moving. The method of securing shall not interfere with the operation of the seat slide being tested. For chairs with an adjustable seat angle, set the angle to its most forward (negative seat slope) angle. Disable any seat depth adjustment locks or interim stops.
- b) A stranded metallic cable or equivalent shall be attached to the most rigid point of the vertical centerline of the seat. This may be accomplished by means of a clamp or similar device that does not affect the test results.
- c) The opposite end of the cable shall extend in line forward from the seat and in line with the plane of the seat movement to a pulley and then downward to an attached weight of 25 kg (55 lb.). Place the seat in its most rearward position and restrain.
- d) Place a 74 kg (163 lb.) rigid mass in the center of the seat.

22.3 Test Procedure

The seat with the hanging weight shall be held at its most rearward position, then released, permitting it to move forward rapidly and impact the out stops. Repeat this procedure for a total of 25 cycles.

22.4 Acceptance Level

There shall be no loss of serviceability to the unit.

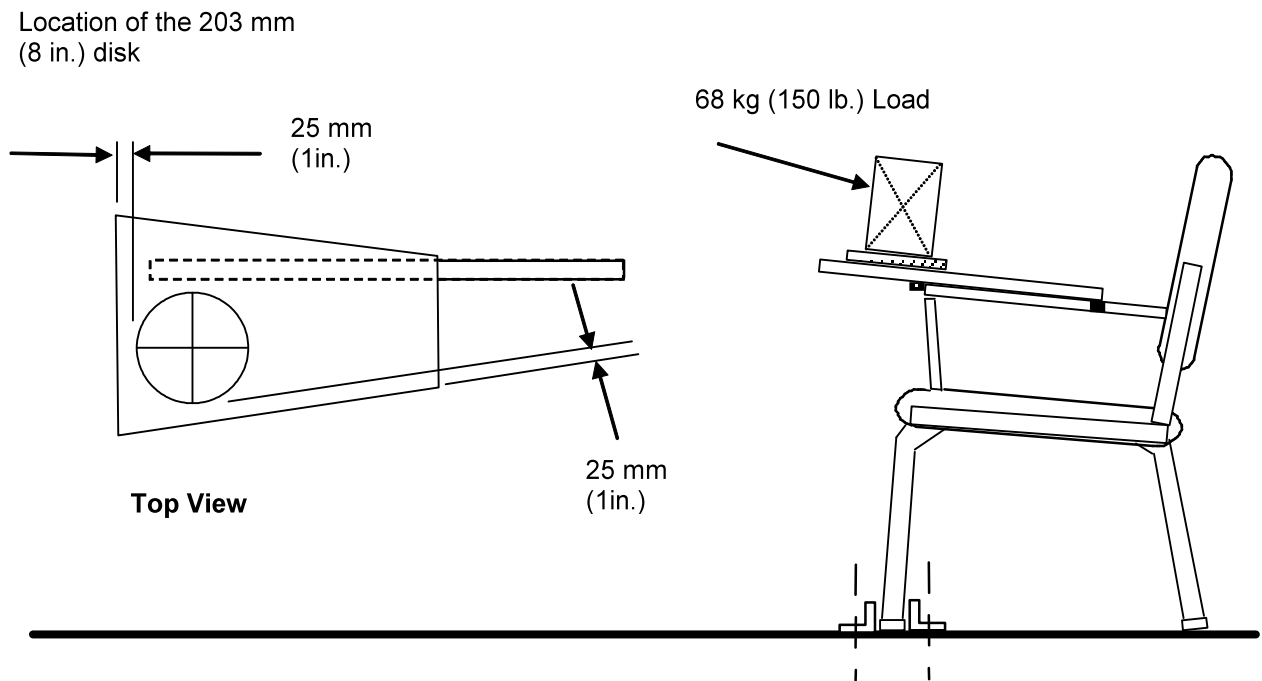

Figure 23 - Tablet Arm Chair Static Load Test

23 Tablet Arm Chair Static Load Test (See Figure 23)

23.1 Purpose of Test

The purpose of this test is to evaluate the ability of the unit equipped with a tablet arm or other attached auxiliary writing/laptop surface to withstand stresses caused by vertical loading.

23.2 Test Setup

- a) The unit shall be placed on a test platform and restrained to prevent movement. Any height adjustment of the chair and/or tablet arm shall be set at the midpoint of adjustment.
- b) Apply the load through a 203 mm \pm 13 mm (8.0 in. \pm 0.51 in.) diameter area 25 mm (1 in.) from the edge of the surface at its apparent weakest point. When the weakest point is not obvious, several load applications may be necessary to properly test the product. If required to prevent tipping of the chair, a counterbalancing force may be applied to the chair seat.

23.3 Test Procedure

Apply a load of 68 kg. (150 lb.) at the location described in 23.2 b) for one (1) minute and remove the load.

23.4 Acceptance Level

The load applied once shall cause no sudden and major change in the structural integrity of the chair. After performing the test, the tablet arm must allow egress from the unit; other losses of serviceability are acceptable.

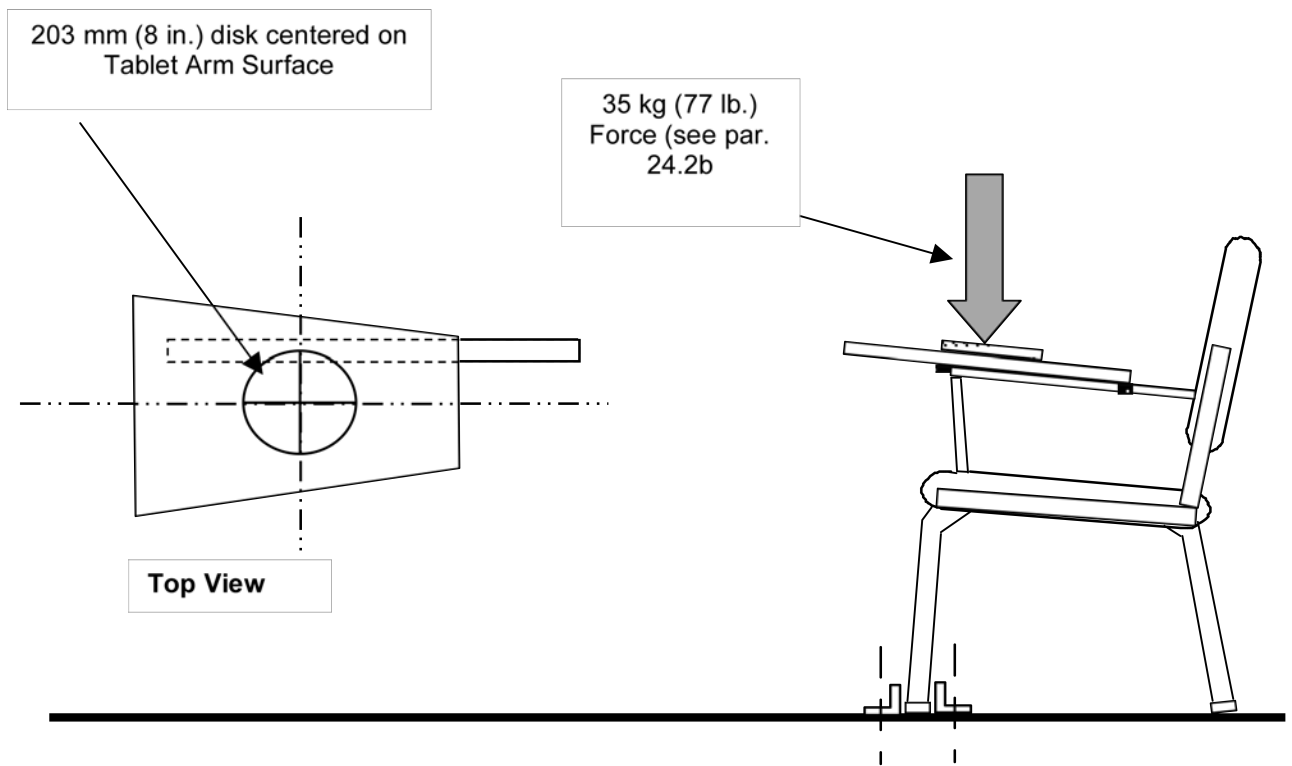

Figure 24 - Tablet Arm Chair Load Ease Test - Cyclic

24 Tablet Arm Chair Load Ease Test - Cyclic (See Figure 24)

24.1 Purpose of Test

The purpose of this test is to evaluate the durability of the tablet arm chair to withstand cyclic loading of the tablet.

24.2 Test Setup

- a) The unit shall be leveled in its normal operating position. The unit shall be placed on a test platform and restrained to prevent movement. Any height adjustment of the chair and/or tablet arm shall be set at the midpoint of adjustment.
- b) A 343 N (77 lbf.) force applied through a 203 mm \pm 13 mm (8.0 in. \pm 0.51 in.) diameter area centered on the writing area of the tablet.
- c) The cycling device shall be set to operate at a rate of 14 \pm 6 cycles per minute.

24.3 Test Procedure

- a) The load shall be raised until the entire weight is off the tablet surface and then eased (without impact) onto the surface, so that it takes the entire weight without any support from the cycling device.
- b) Repeat Step (a) for a total of 100,000 cycles.

24.4 Acceptance Level

There shall be no loss of serviceability to the chair and/or tablet arm.

Appendix A

Impact Test Bag Construction Details

Example: 406 mm (16 in.) diameter bag

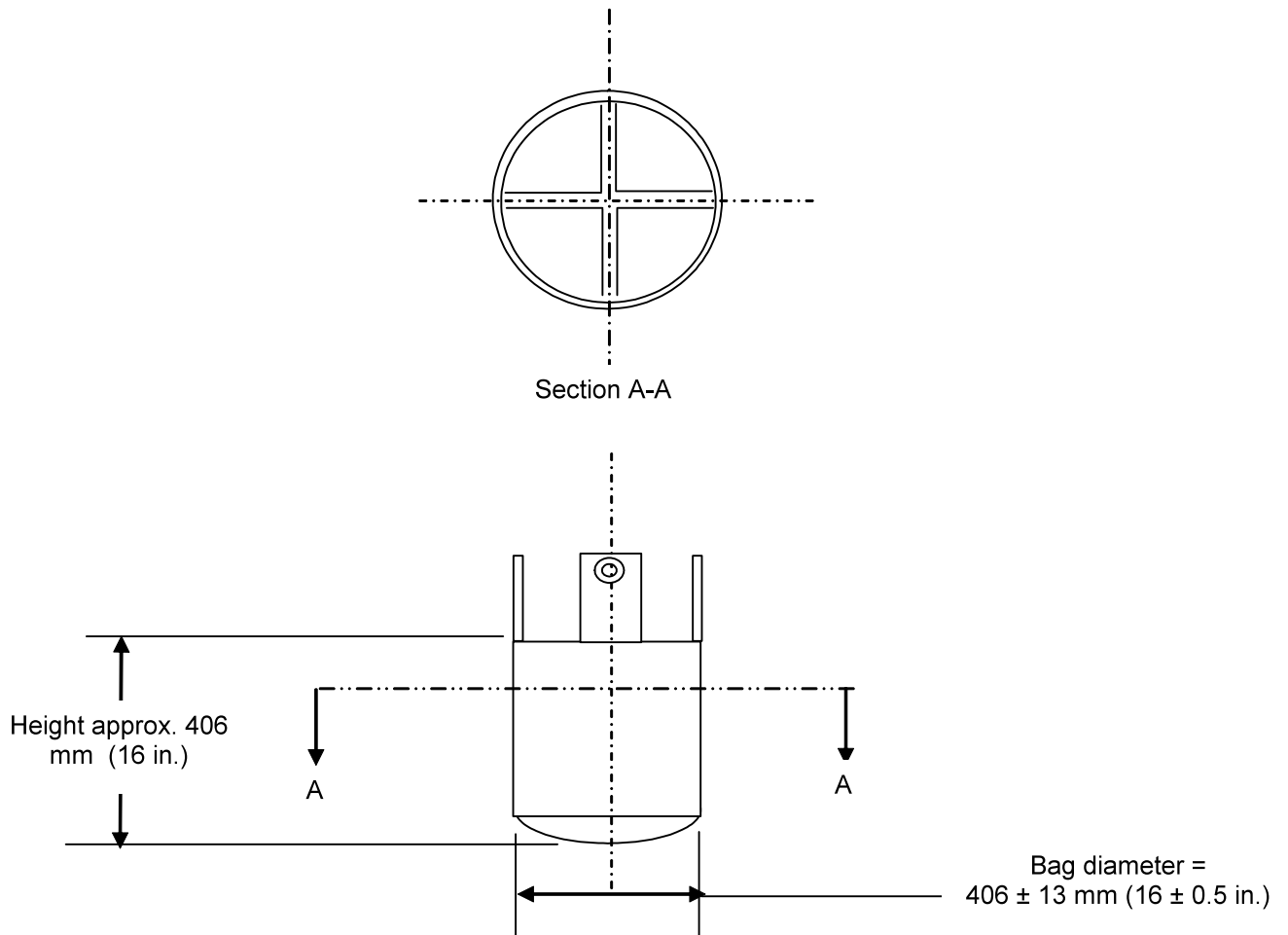

Bag to contain a sufficient quantity of media to bring the bag to the specified load. Media may be shot, slugs, punches, sand, etc. Media may be contained within smaller individual bags/compartments. Media may not be a singular solid material (e.g. single steel or concrete mass).

Note: For health and environmental reasons, lead shot is not recommended. Other fixtures or media are acceptable if they provide an equivalent impact.

Appendix A continued
Impact Test Bag – Typical Construction

DROP BAG

DET NO	DESCRIPTION	MATERIAL	QTY
1	SIDE PANEL	22 OZ. VINYL COATED POLYESTER	1
2	BOTTOM PANEL	22 OZ. VINYL COATED POLYESTER	2
3	INSIDE PANEL	22 OZ. VINYL COATED POLYESTER	1
4	REINFORCEMENT	22 OZ. VINYL COATED POLYESTER	4
5	WEBBING	2" WIDE POLYESTER, ABRASION GRADE, TENSILE STRENGTH OF 2900 LBS.	2
6	THREAD	POLYESTER #305	X
7	STEEL RINGS	3/8" DIA. STOCK x 2-3/8" WIDE x 3-1/8" HIGH	4

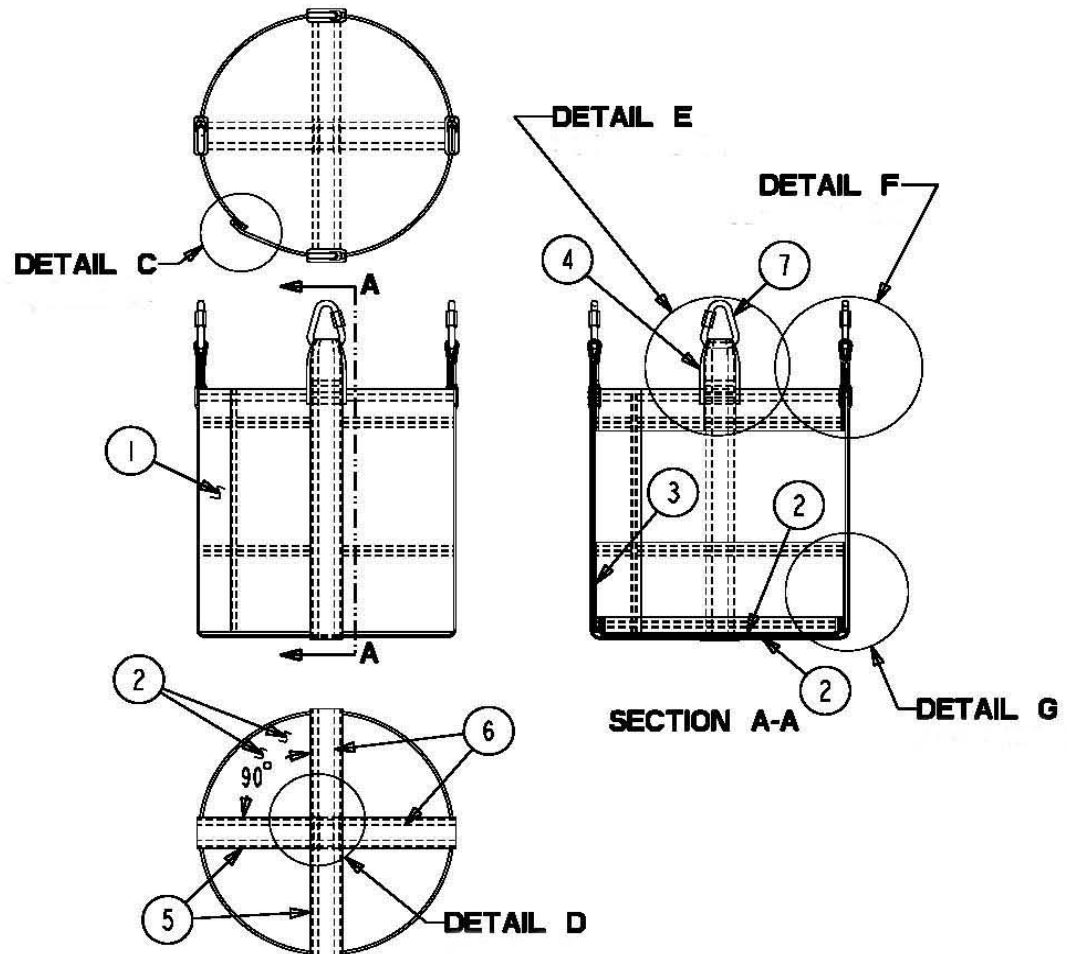

Impact Test Bag - Typical Construction

DROP BAG

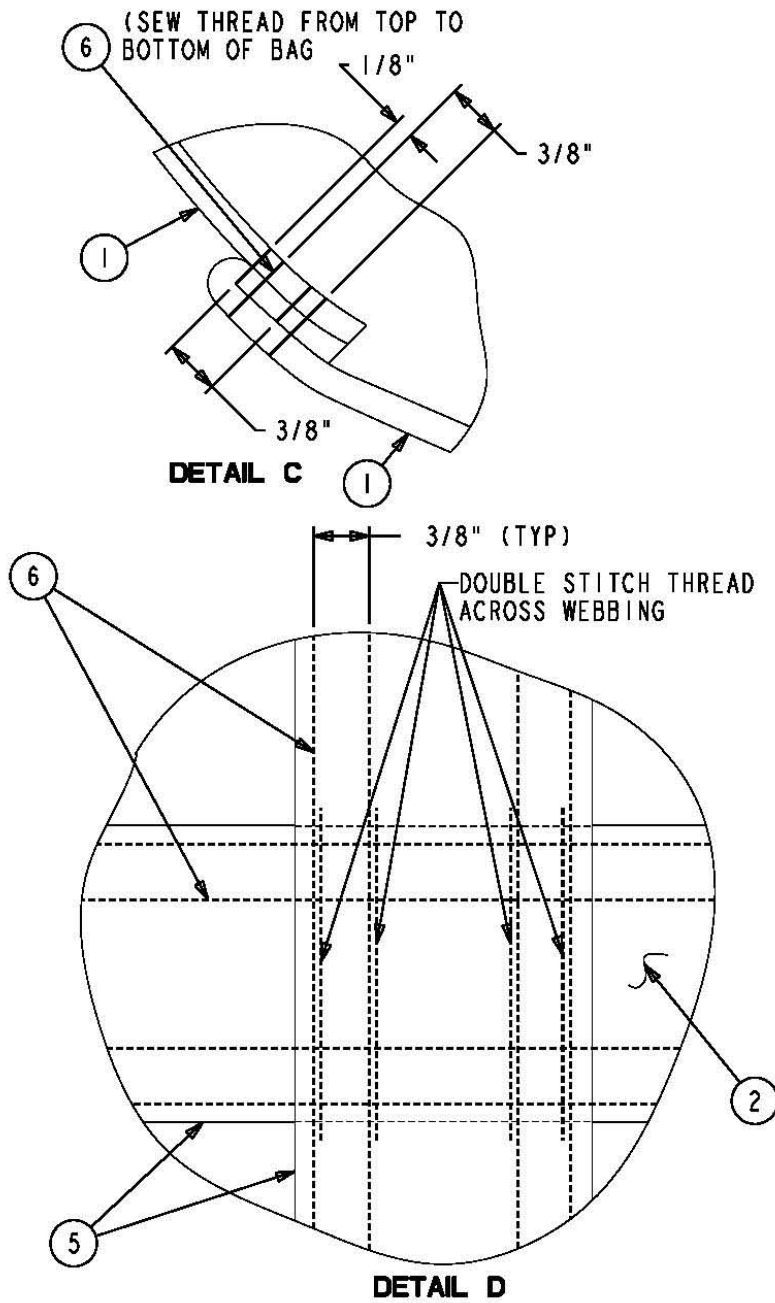

Impact Test Bag - Typical Construction

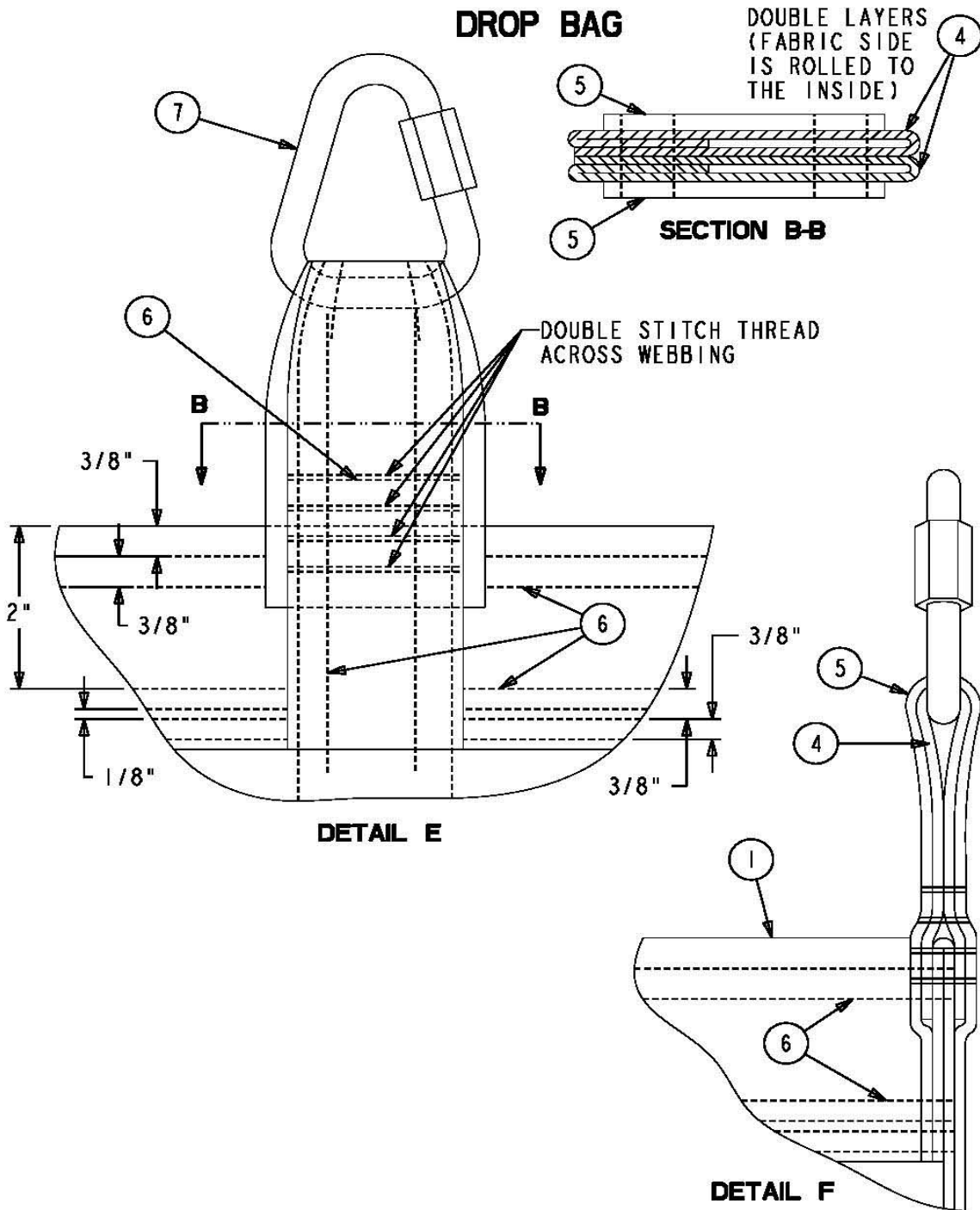

Impact Test Bag - Typical Construction

DROP BAGBAG CONSTRUCTION:

1. THE BAG IS TO BE SEWN TO BE 16" OUTSIDE DIAMETER AND 16" DEEP.
2. THE BAG IS CONSTRUCTED AS SHOWN ON ALL SHEETS.
3. THE TWO LIFTING STRAPS ARE OF 2" WIDE POLYESTER WEBBING SEWN IN AT 90° TO ONE ANOTHER ON THE OUTSIDE OF THE BAG.
4. THEY EXTEND DOWN ONE SIDE OF THE BAG, UNDER THE BOTTOM AND UP THE OTHER SIDE.
5. THE STEEL LIFTING RINGS ARE SEWN INTO THE FOUR ENDS OF THE TWO STRAPS.

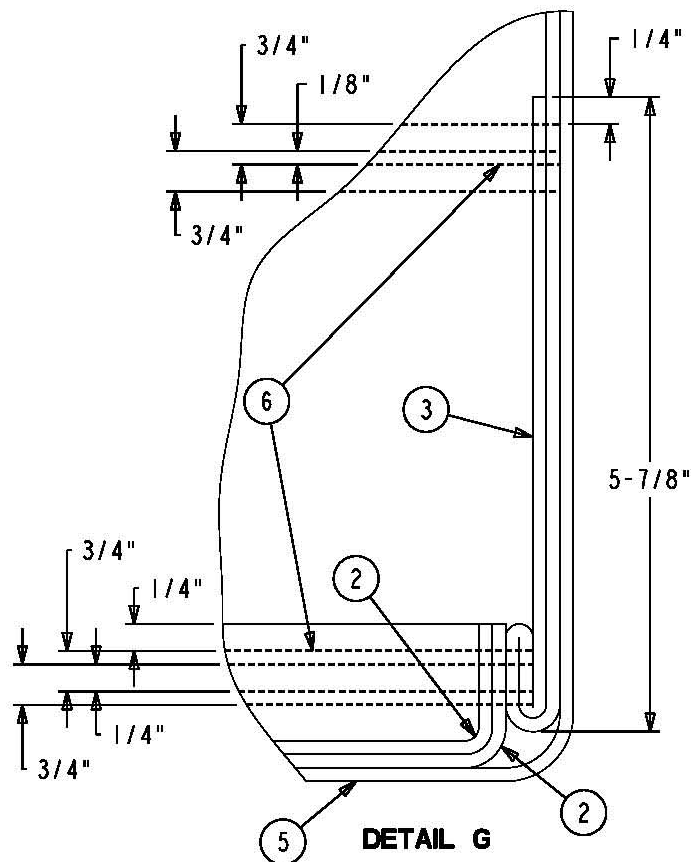

Test Bag Handling Suggestions:

Support fixtures for lifting and attaching the bag to test devices may be used to help maintain the shape of the bag and provide improved consistency, depending on the media chosen.

Examples of support fixtures are shown below:

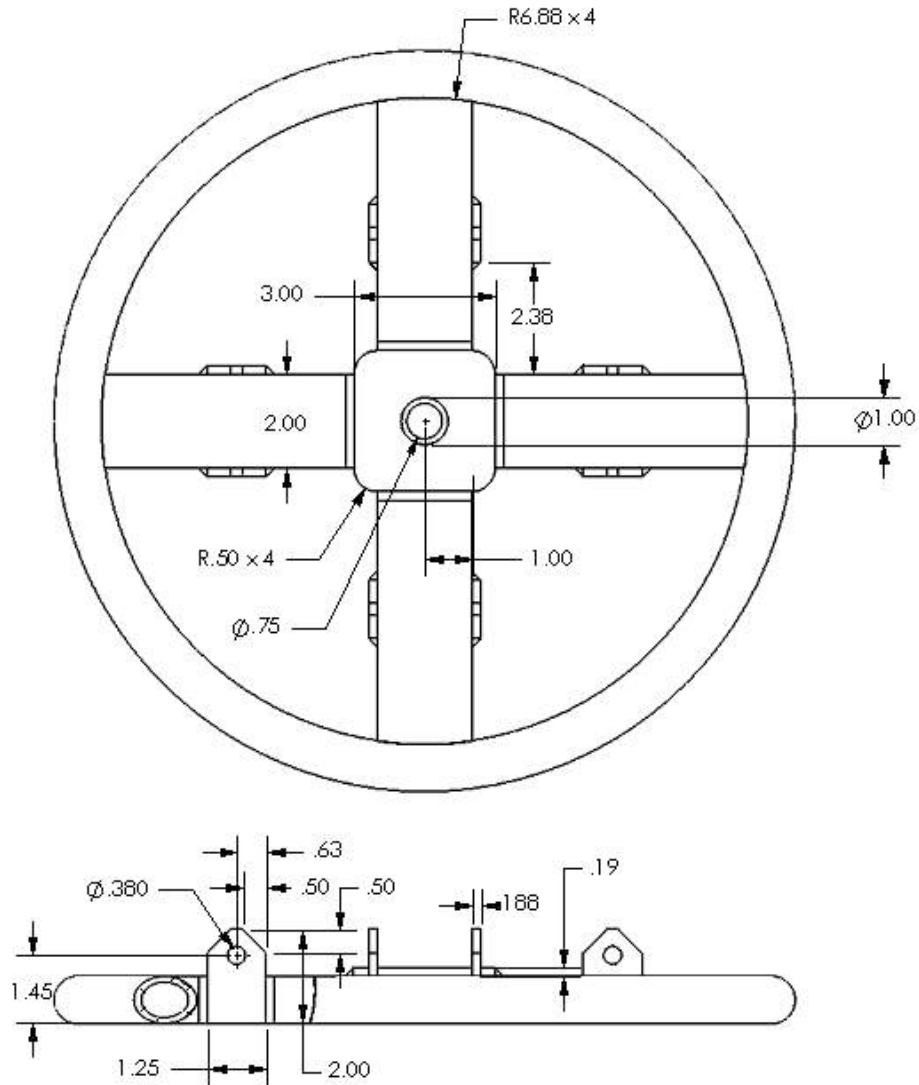

Appendix A continued

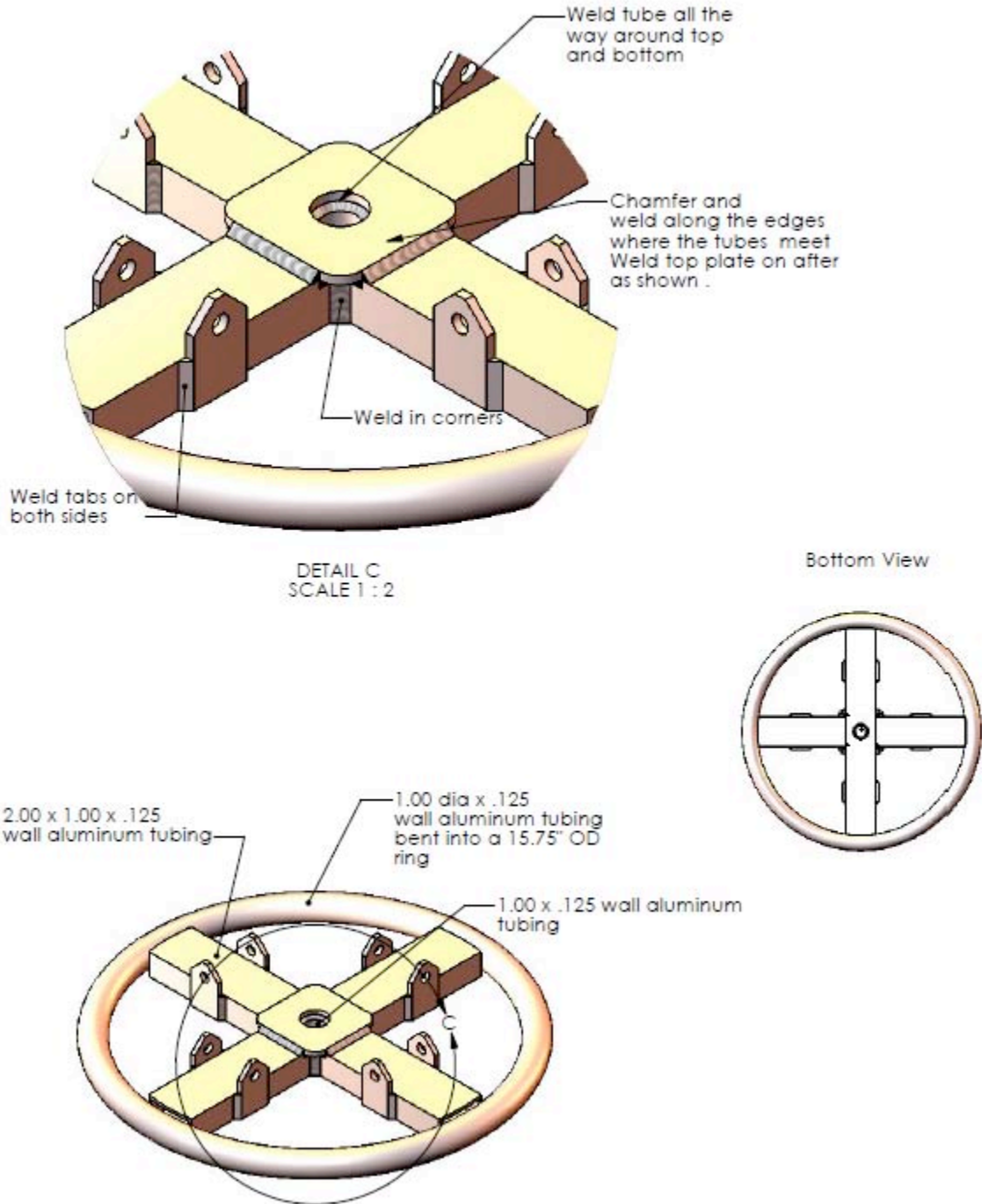

Note: Other designs may be used to help maintain the shape of the bag and provide improved consistency.

**Appendix B
Stability Disk – Construction Details**

The disks shall weigh $10 \text{ kg} \pm 0.05 \text{ kg}$ ($22 \text{ lb.} \pm 0.11 \text{ lb.}$) each, having a diameter of 350 mm (13.8 in.) and a thickness of 48 mm (1.9 in.). The center of gravity shall be in the center of the disk. The surface friction of the disk (disk to disk) shall be such that the static sliding force shall be $31 \text{ N} \pm 9 \text{ N}$ ($7 \text{ lbf} \pm 2 \text{ lbf.}$).

One acceptable construction of the disk is a sandwich construction consisting of two medium density fiberboard (mdf) outer plates with steel plates sandwiched in between them. The steel plates have through holes drilled out for the screws and additional holes symmetrically drilled to achieve the total weight required. The entire construction is held together with counter-sink screws into threaded inserts.

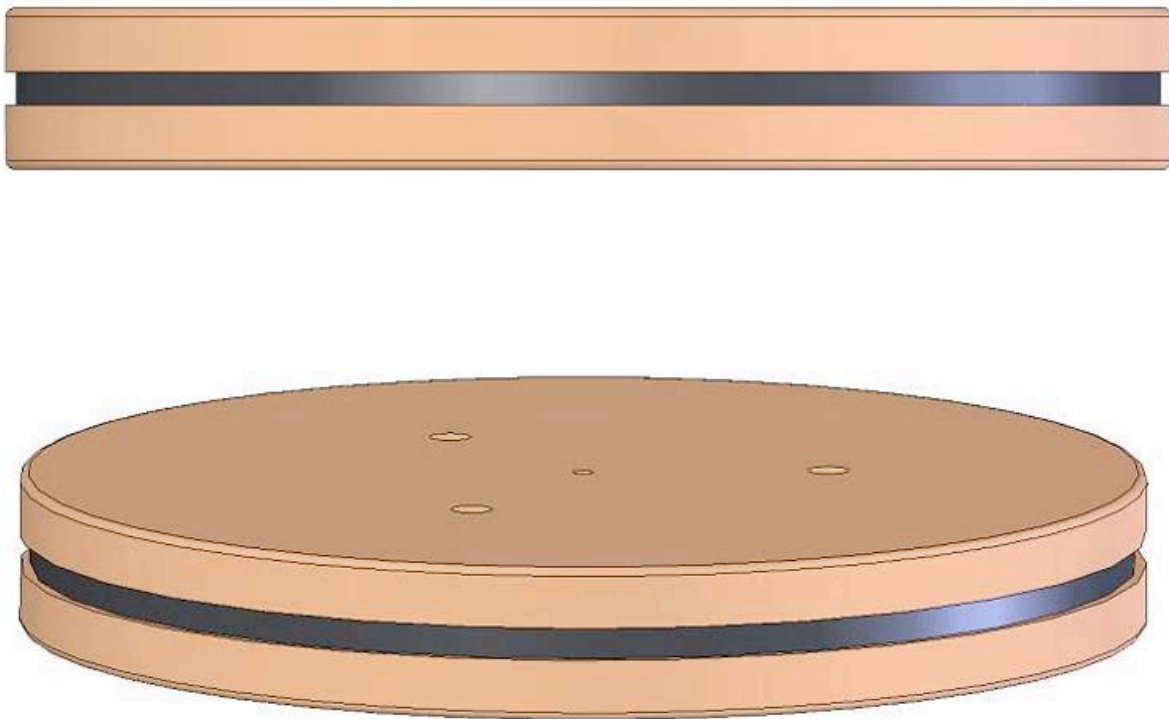

One acceptable construction of the disk

End of Document